

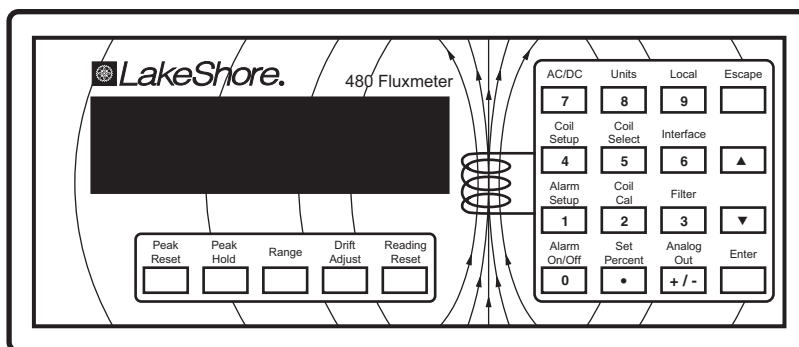

# User's Manual

## Model 480

### Fluxmeter



Lake Shore Cryotronics, Inc.  
575 McCorkle Blvd.  
Westerville, Ohio 43082-8888 USA

Internet E-mail:  
[sales@lakeshore.com](mailto:sales@lakeshore.com)  
[service@lakeshore.com](mailto:service@lakeshore.com)

Visit our website at:  
[www.lakeshore.com](http://www.lakeshore.com)

Fax: (614) 891-1392  
Telephone: (614) 891-2243

Methods and apparatus disclosed and described herein have been developed solely on company funds of Lake Shore Cryotronics, Inc. No government or other contractual support or relationship whatsoever has existed which in any way affects or mitigates proprietary rights of Lake Shore Cryotronics, Inc. in these developments. Methods and apparatus disclosed herein may be subject to U.S. Patents existing or applied for. Lake Shore Cryotronics, Inc. reserves the right to add, improve, modify, or withdraw functions, design modifications, or products at any time without notice. Lake Shore shall not be liable for errors contained herein or for incidental or consequential damages in connection with furnishing, performance, or use of this material.

### **LIMITED WARRANTY**

Lake Shore Cryotronics, Inc. (henceforth Lake Shore), the manufacturer, warrants this product to be free from defects in material or workmanship for a period of twelve (12) months from the date of shipment. During the warranty period, under authorized return of instruments or component parts to Lake Shore freight prepaid, the company will repair, or at its option replace, any part found to be defective in material or workmanship, without charge to the owner for parts, service labor or associated customary return shipping cost. Replacement or repaired parts will be warranted for only the unexpired portion of the original warranty or 90 days (whichever is greater).

All products are thoroughly tested and calibrated to published specifications prior to shipment. Calibration Certifications are offered for six month periods only. Where such documentation must be updated, a re-certification service is offered by Lake Shore at a reasonable cost.

### **LIMITATION OF WARRANTY**

This warranty does not apply to defects resulting from improper installation, product modifications made by others without Lake Shore's express written consent, or from misuse of any product or part. This warranty also does not apply to fuses, software, non-rechargeable batteries, or problems arising from normal wear or failure to follow instructions.

This warranty is in lieu of any other warranties, expressed or implied, including merchantability, or fitness for a particular purpose, which are expressly excluded. The owner agrees that Lake Shore's liability with respect to this product shall be set forth in this warranty, and incidental or consequential damages are expressly excluded.

### **CERTIFICATION**

Lake Shore certifies that this product has been inspected and tested in accordance with its published specifications and that this product met its published specifications at the time of shipment. The accuracy and calibration of this product at the time of shipment are traceable to the United States National Institute of Standards and Technology (NIST); formerly known as the National Bureau of Standards (NBS).

### **FIRMWARE LIMITATIONS**

Lake Shore has worked to ensure that the Model 480 firmware is as free of errors as possible, and that the results you obtain from the instrument are accurate and reliable. However, as with any computer-based software, the possibility of errors exists.

In any important research, as when using any laboratory equipment, results should be carefully examined and rechecked before final conclusions are drawn. Neither Lake Shore nor anyone else involved in the creation or production of this firmware can pay for loss of time, inconvenience, loss of use of the product, or property damage caused by this product or its failure to work, or any other incidental or consequential damages. Use of our product implies that you understand the Lake Shore license agreement and statement of limited warranty.

### **FIRMWARE LICENSE AGREEMENT**

The firmware in this instrument is protected by United States copyright law and international treaty provisions. To maintain the warranty, the code contained in the firmware must not be modified. Any changes made to the code is at the user's risk. Lake Shore will assume no responsibility for damage or errors incurred as result of any changes made to the firmware.

Under the terms of this agreement you may only use the Model 480 firmware as physically installed in the instrument. Archival copies are strictly forbidden. You may not decompile, disassemble, or reverse engineer the firmware. If you suspect there are problems with the firmware, return the instrument to Lake Shore for repair under the terms of the Limited Warranty specified above. Any unauthorized duplication or use of the Model 480 firmware in whole or in part, in print, or in any other storage and retrieval system is forbidden.

### **TRADEMARK ACKNOWLEDGMENT**

Many manufacturers and sellers claim designations used to distinguish their products as trademarks. Where those designations appear in this manual and Lake Shore was aware of a trademark claim, they appear with initial capital letters and the <sup>™</sup> or <sup>®</sup> symbol.

CalCurve<sup>™</sup>, Carbon-Glass<sup>™</sup>, Cernox<sup>™</sup>, Duo-Twist<sup>™</sup>, DriftTrak<sup>™</sup>, Quad-Lead<sup>™</sup>, Quad-Twist<sup>™</sup>, and SoftCal<sup>™</sup> are trademarks of Lake Shore Cryotronics, Inc.

MS-DOS<sup>®</sup> and Windows/95/98/NT<sup>®</sup> are trademarks of Microsoft Corporation.

NI-488.2<sup>™</sup> is a trademark of National Instruments.

PC, XT, AT, and PS-2 are trademarks of IBM.

Copyright © 1999–2001 and 2004 by Lake Shore Cryotronics, Inc. All rights reserved. No portion of this manual may be reproduced, stored in a retrieval system, or transmitted, in any form or by any means, electronic, mechanical, photocopying, recording, or otherwise, without the express written permission of Lake Shore.



## DECLARATION OF CONFORMITY

We: **Lake Shore Cryotronics, Inc.**  
**575 McCorkle Blvd.**  
**Westerville OH 43082-8888 USA**

hereby declare that the equipment specified conforms to the following Directives and Standards:

Application of Council Directives: ..... **73/23/EEC**  
**89/336/EEC**

Standard to which Conformity is declared: ..... **EN 61010-1:2001**  
Overvoltage II  
Pollution Degree 2  
**EN 61326 A2:2001**  
Class A  
Annex B

Model Number: ..... **480**

1-7-2004

**Ed Maloof**  
*Printed Name*

**Vice President of Engineering**  
*Position*

### **Electromagnetic Compatibility (EMC) for the Model 480 Fluxmeter**

Electromagnetic Compatibility (EMC) of electronic equipment is a growing concern worldwide. Emissions of and immunity to electromagnetic interference is now part of the design and manufacture of most electronics. To qualify for the CE Mark, the Model 480 meets or exceeds the generic requirements of the European EMC Directive 89/336/EEC as a **CLASS A** product. A Class A product is allowed to radiate more RF than a Class B product and must include the following warning:

**WARNING: This is a Class A product. In a domestic environment, this product may cause radio interference in which case the user may be required to take adequate measures.**

The instrument was tested under normal operating conditions with sensor and interface cables attached. If the installation and operating instructions in the User's Manual are followed, there should be no degradation in EMC performance.

Pay special attention to instrument cabling. Improperly installed cabling may defeat even the best EMC protection. For the best performance from any precision instrument, follow the grounding and shielding instructions in the User's Manual. In addition, the installer of the Model 480 should consider the following:

- Leave no unused or unterminated cables attached to the instrument.
- Make cable runs as short and direct as possible.
- Do not tightly bundle cables that carry different types of signals.

# Table of Contents

<i>Chapter/Paragraph</i>	<i>Title</i>	<i>Page</i>
<b>1</b>	<b>INTRODUCTION .....</b>	<b>1-1</b>
1.0	GENERAL .....	1-1
1.1	PRODUCT DESCRIPTION.....	1-1
1.2	SPECIFICATIONS .....	1-2
1.3	SAFETY SUMMARY .....	1-4
1.4	SAFETY SYMBOLS.....	1-4
<b>2</b>	<b>MAGNETIC MEASUREMENT OVERVIEW.....</b>	<b>2-1</b>
2.0	GENERAL .....	2-1
2.1	INTEGRATING INSTRUMENTS .....	2-1
2.1.1	What Is An Integrator?.....	2-1
2.1.2	Why Integrators Are Used For Magnetic Measurement .....	2-1
2.1.3	Important Integrator Characteristics .....	2-2
2.1.4	Reducing Integrator Drift.....	2-3
2.1.5	Dielectric Absorption .....	2-3
2.1.6	Analog Versus Digital Integrators .....	2-4
2.1.7	Fluxmeter Measurements in Magnetizers .....	2-4
2.1.8	Making AC Measurements .....	2-6
2.2	COIL CHARACTERISTICS.....	2-6
2.2.1	Coil Sensitivity.....	2-6
2.2.2	Coil Size.....	2-7
2.2.3	Coil Resistance .....	2-7
2.2.4	Coil Temperature Coefficient .....	2-8
2.2.5	Coil Orientation .....	2-8
2.2.6	Field Uniformity .....	2-9
2.2.7	Lead Pickup .....	2-9
2.2.8	Inductance, Capacitance, and Self Resonance.....	2-9
2.2.9	Lake Shore Coils and Probes .....	2-9
2.3	FLUX OVERVIEW.....	2-10
2.4	FLUX DENSITY OVERVIEW.....	2-10
2.4.1	What is Flux Density? .....	2-10
2.4.2	How Flux Density (B) Differs from Magnetic Field Strength (H).....	2-11
2.5	MAGNETIC MOMENT OVERVIEW.....	2-11
2.5.1	What is Magnetic Moment? .....	2-11
2.5.2	Important Parameters of a Hemholtz Coil .....	2-11
2.5.3	Hemholtz Coil Constant Determination (For Non-Lake Shore Coils).....	2-12
2.6	MAGNETIC POTENTIAL OVERVIEW.....	2-13
2.6.1	What is Magnetic Potential? .....	2-13
2.6.2	Important Parameters of a Potential Coil.....	2-13
<b>3</b>	<b>SETUP.....</b>	<b>3-1</b>
3.0	GENERAL .....	3-1
3.1	RECEIVING THE MODEL 480 .....	3-1
3.1.1	Inspection and Unpacking .....	3-1
3.1.2	Repackaging For Shipment .....	3-1
3.2	REAR PANEL DEFINITION .....	3-2
3.3	LINE INPUT ASSEMBLY .....	3-2
3.3.1	Line Voltage and Fuse Verification.....	3-2

## TABLE OF CONTENTS (Continued)

<i>Chapter/Paragraph</i>	<i>Title</i>	<i>Page</i>
3.3.2	Power Cord .....	3-2
3.3.3	Power Switch.....	3-2
3.4	COIL INPUT CONNECTION .....	3-3
3.5	PROBE INPUT CONNECTION .....	3-3
3.5.1	Attachment To A Non-Lake Shore Coil .....	3-3
3.6	TERMINAL BLOCK .....	3-4
3.6.1	Alarm Relay Connection.....	3-4
3.6.2	Analog Output Connections .....	3-4
3.6.3	External Reset Connections.....	3-4
3.6.4	Optional Input Connection.....	3-4
<b>4</b>	<b>BASIC OPERATION.....</b>	<b>4-1</b>
4.0	GENERAL.....	4-1
4.1	TURNING ON POWER .....	4-1
4.2	DISPLAY DEFINITION .....	4-1
4.3	READING FORMAT .....	4-2
4.4	KEYPAD DEFINITION.....	4-2
4.5	GENERAL KEYPAD OPERATION .....	4-3
4.6	QUICK START PROCEDURES .....	4-4
4.6.1	DC Integrator Measurement In Units of V·s, WbN, or MxN .....	4-4
4.6.2	DC Flux Measurement In Units of V·sφ, Mx, or Wb .....	4-5
4.6.3	DC Flux Density Measurement In Units of G or T.....	4-6
4.6.4	Moment Measurement In Unit of Wb·cm.....	4-7
4.6.5	Potential Measurement In Unit of A .....	4-8
<b>5</b>	<b>ADVANCED OPERATION .....</b>	<b>5-1</b>
5.0	GENERAL.....	5-1
5.1	UNITS SELECTION .....	5-1
5.2	COIL PARAMETERS .....	5-2
5.3	COIL SETUP .....	5-2
5.3.1	Input Resistance.....	5-3
5.3.2	Coil Resistance .....	5-4
5.3.3	Number of Turns (N) .....	5-4
5.3.4	Area (A).....	5-4
5.3.5	Area Turns (AN).....	5-5
5.3.6	Helmholtz Constant.....	5-5
5.3.7	Potential Constant.....	5-5
5.4	MAKING MEASUREMENTS IN PERCENT .....	5-6
5.4.1	Before Using Set Percent.....	5-6
5.4.2	Set Percent (%).....	5-6
5.4.3	Percent Scale Factor.....	5-6
5.5	COIL CALIBRATION .....	5-7
5.5.1	Before using Coil Calibration.....	5-7
5.5.2	Calibrating a Coil .....	5-7
5.6	COIL SELECT AND PARAMETER STORAGE .....	5-7
5.6.1	Storing New Coil Parameters into Instrument Memory.....	5-8
5.6.2	Storing New Coil Parameters into Probe Memory .....	5-8
5.6.3	Selecting Saved Coil Parameters .....	5-8

## TABLE OF CONTENTS (Continued)

<i>Chapter/Paragraph</i>	<i>Title</i>	<i>Page</i>
5.7	RANGE SELECTION.....	5-9
5.8	READING RESET.....	5-9
5.9	DRIFT ADJUSTMENT .....	5-10
5.9.1	Automatic Drift Adjustment .....	5-10
5.9.2	Manual Drift Adjustment .....	5-11
5.9.3	DriftTrak™.....	5-11
5.10	DC AND AC MEASUREMENT MODES.....	5-12
5.10.1	DC Measurement Mode.....	5-12
5.10.2	AC Measurement Mode.....	5-13
5.11	PEAK HOLD AND PEAK RESET .....	5-14
5.11.1	Peak Hold in DC Mode .....	5-14
5.11.2	Peak Hold in AC Mode .....	5-14
5.11.3	Activating Peak Mode.....	5-14
5.11.4	Peak Reset .....	5-15
5.11.5	Choosing Positive, Negative or Both Peaks.....	5-15
5.12	FILTER.....	5-15
5.13	DISPLAY RESOLUTION .....	5-16
5.14	ALARM AND RELAY OPERATION.....	5-16
5.14.1	Alarm Setup.....	5-17
5.14.2	Relay Setup .....	5-18
5.14.3	Turning Alarm On and Off.....	5-19
5.15	ANALOG OUT OPERATION .....	5-19
5.15.1	Corrected Analog Output.....	5-19
5.15.2	Monitor Analog Output.....	5-20
5.16	EXTERNAL RESET .....	5-21
5.17	OPTIONAL INPUT .....	5-21
5.18	LOCKING AND UNLOCKING THE KEYPAD.....	5-21
5.19	RESETTING TO DEFAULT VALUES.....	5-22
<b>6</b>	<b>COMPUTER INTERFACE OPERATION.....</b>	<b>6-1</b>
6.0	GENERAL.....	6-1
6.1	IEEE-488 INTERFACE .....	6-1
6.1.1	IEEE-488 Interface Settings .....	6-2
6.1.2	IEEE-488 Command Structure .....	6-2
6.1.3	Status Registers .....	6-3
6.1.4	Example IEEE Setup and Program .....	6-5
6.1.5	Notes on Using the IEEE Interface.....	6-5
6.2	SERIAL I/O INTERFACE .....	6-8
6.2.1	Serial Interface Hardware Configuration .....	6-8
6.2.2	Serial Interface Settings.....	6-8
6.2.3	Sample BASIC Serial Interface Program.....	6-9
6.2.4	Notes on Using the Serial Interface.....	6-9
6.3	IEEE-488/SERIAL INTERFACE COMMAND SUMMARY.....	6-11
6.3.1	Command List Structure.....	6-12
6.3.2	IEEE-488/Serial Interface Commands (Alphabetical Listing).....	6-12

## TABLE OF CONTENTS (Continued)

<i>Chapter/Paragraph</i>	<i>Title</i>	<i>Page</i>
<b>7</b>	<b>ACCESSORIES, COILS, AND PROBES</b>	<b>7-1</b>
7.0	GENERAL	7-1
7.1	ACCESSORIES	7-1
7.2	FIELD MEASURING PROBES	7-3
7.2.1	100 cm <sup>2</sup> Field Probe	7-3
7.2.2	30 cm <sup>2</sup> Field Probe	7-4
7.3	HELMHOLTZ COILS	7-5
7.4	REFERENCE MAGNETS	7-7
<b>8</b>	<b>SERVICE</b>	<b>8-1</b>
8.0	GENERAL	8-1
8.1	GENERAL MAINTENANCE PRECAUTIONS	8-1
8.2	ELECTROSTATIC DISCHARGE	8-1
8.2.1	Identification of Electrostatic Discharge Sensitive Components	8-2
8.2.2	Handling Electrostatic Discharge Sensitive Components	8-2
8.3	LINE VOLTAGE SELECTION	8-2
8.4	FUSE REPLACEMENT	8-3
8.5	REAR PANEL CONNECTOR DEFINITIONS	8-4
8.5.1	Serial Interface Cable Wiring	8-6
8.5.2	IEEE-488 Interface Connector	8-7
8.6	TOP OF ENCLOSURE REMOVAL AND REPLACEMENT	8-8
8.6.1	Removal Procedure	8-8
8.6.2	Installation Procedure	8-8
8.7	EPROM REPLACEMENT	8-8
8.8	ERROR MESSAGES	8-9
8.9	CALIBRATION PROCEDURE	8-10
8.9.1	Required Equipment List	8-10
8.9.2	A/D Reference Voltages	8-10
8.9.3	Initialize for Calibration	8-10
8.9.4	AC Peak Offset	8-11
8.9.5	AC RMS and AC Peak Gain Calibration	8-11
8.9.6	DC and DC Peak Calibration	8-12
8.9.7	Output Calibration	8-13
8.9.8	Finalize Calibration	8-14
<b>APPENDIX A – GLOSSARY OF TERMINOLOGY</b>		<b>A-1</b>
<b>APPENDIX B – UNITS FOR MAGNETIC PROPERTIES</b>		<b>B-1</b>

## LIST OF ILLUSTRATIONS

<i>Figure No.</i>	<i>Title</i>	<i>Page</i>
3-1	Model 480 Rear Panel .....	3-2
3-2	Line Input Assembly .....	3-3
4-1	Model 480 Normal Display Definition .....	4-1
4-2	Model 480 Front Panel .....	4-2
5-1	Model 480 AC Frequency Response .....	5-13
5-2	Examples of Alarm Activation Inside and Outside High and Low Setpoints .....	5-18
6-1	Typical National Instruments GPIB Configuration from IBCONF.EXE .....	6-7
7-1	100 cm <sup>2</sup> Field Probe .....	7-3
7-2	30 cm <sup>2</sup> Field Probe .....	7-4
7-3	Model FH-2.5 Helmholtz Coil .....	7-5
7-4	Model FH-6 Helmholtz Coil .....	7-6
7-5	Model FH-12 Helmholtz Coil .....	7-6
7-6	Lake Shore Reference Magnets .....	7-7
7-7	Model RM-1/2 Half-Rack Mounting Kit .....	7-8
7-8	Model RM-2 Dual Rack-Mount Shelf .....	7-8
8-1	Power Fuse Access .....	8-3
8-2	COIL INPUT Connector Details .....	8-4
8-3	PROBE INPUT Connector Details .....	8-4
8-4	Relays and Analog Signals Terminal Block .....	8-5
8-5	SERIAL I/O Connector Details .....	8-5
8-6	IEEE-488 Rear Panel Connector Details .....	8-7
8-7	Location of Operating Software EPROM .....	8-9

## LIST OF TABLES

<i>Table No.</i>	<i>Title</i>	<i>Page</i>
2-1	Examples of Copper Wire Resistance .....	2-8
3-1	Sample AC Line Input List .....	3-3
5-1	Units and Associated Coil Parameters .....	5-1
5-2	Default Values .....	5-22
6-1	Sample BASIC IEEE-488 Interface Program .....	6-6
6-2	Serial Interface Specifications .....	6-8
6-3	Sample BASIC Serial Interface Program .....	6-10
8-1	AC Calibration Table .....	8-11
8-2	DC Calibration Table .....	8-12

This Page Intentionally Left Blank

# CHAPTER 1

## INTRODUCTION

### 1.0 GENERAL

This chapter provides introductory information for the Lake Shore Model 480 Fluxmeter. Product description is in Paragraph 1.1, specifications in Paragraph 1.2, safety summary in Paragraph 1.3, and safety symbols in Paragraph 1.4.

### 1.1 PRODUCT DESCRIPTION

The Model 480 is a precision integrating fluxmeter that works with a variety of sensing coils to measure changing flux. It is fundamentally an analog integrator under microprocessor control. The analog integrator has excellent specifications and is very flexible. It performs well in a variety of magnet applications from a fast pulse to a slow ramp. The microprocessor optimizes the performance of the integrator and enables numerous features and interfaces. The Model 480 fits well into test and measurement operations from all manual to fully automated with quick setup and ease of use. The fluxmeter complements the existing line of Lake Shore gaussmeters.

#### **Manual Magnet Testing**

A bright display and fast reading update make the Model 480 ideal for manual magnet sorting and testing. The low drift of the instrument improves productivity with fewer adjustments. Remote terminals allow for foot pedal reading reset to keep hands on the work, not the instrument. Configurable alarms give an audible signal or relay closure to signify pass/fail.

#### **Automated Magnet Testing**

In automated testing, time is money. The Model 480 has many features to enhance throughput. The instrument has a fast update rate and settling time. It recovers quickly from reading reset to start a new reading cycle. IEEE-488 and serial computer interfaces included with the Model 480 can be used to control most instrument functions. Relays and analog outputs can be used for automation without a computer interface.

#### **Magnetizing**

The magnetizing process places unique demands on all associated electronics. The Model 480 responds with very fast peak capture that can keep up with the fastest magnetizing pulses. Both a positive and negative peak can be captured from the same pulse. The input of the Model 480 is protected against the high voltages at its input present during magnetizing.

#### **Materials Analysis**

High resolution and low drift define a the role of the fluxmeter in analytical measurement. The high resolution of the Model 480 is reinforced by a low noise floor. A configurable filter helps keep the readings quiet. Automatic and manual drift adjustment modes help optimize the low-drift characteristics of the integrators. The IEEE-488 and serial computer interfaces included with the Model 480 allow automated data taking.

#### **AC Magnetic Fields**

Sensing coils are sensitive to AC magnetic fields but many conventional integrating fluxmeters can not measure AC fields. The Model 480 has an AC mode that enables it to measure fields over a wide frequency range using simple sensing coils. Applications are limited to field volumes as large or larger than the coil but for some, it is an inexpensive way to make low drift AC field measurements.

#### **Drift Adjustment**

Adjusting or nulling the drift of an analog integrator wastes time. It can be the only unpleasant part of using an integrating fluxmeter. Lake Shore innovation brings some relief. The Model 480 has a built in drift algorithm that continually adjusts drift when the instrument and coil are idle. It is ready when you are to make precision low drift measurements. The adjustment algorithm has no effect during flux integration. Manual drift adjustment is also available.

#### **Coils and Probes**

Coils and probes wound by the user or from other manufacturers can easily be used with the Model 480. The Model 480 allows the user to save parameters for up to 10 existing coils/probes and quickly switch between them. Lake Shore also offers several sensing coils and probe assemblies for use with the Model 480 which offer several conveniences. They are factory calibrated for accuracy and interchangeability. Calibration data is loaded into memory in the probe connector so it does not have to be entered by the user. Special coil assemblies are also available and can be designed to meet customer specifications.

## 1.2 SPECIFICATIONS

### Measurement

Number Of Inputs: 1

Input Type: Two-lead, ground referenced

Input Resistance: 100 k $\Omega$  or 10 k $\Omega$

Maximum Operating Input Voltage: 60 V

Absolute Maximum Input Voltage: 100 V; WARNING: Voltages between 60 V and 100 V will not damage the instrument but could result in damage to other instruments or personal injury.

Update Rate: 5 readings per second on display, 30 readings per second IEEE-488, 30 readings per second serial

### DC

DC Display Resolution: To 5 $\frac{1}{4}$  digits

DC Integrator Capacitance: 1  $\mu$ F nominal

DC Input Resistance:	100 k $\Omega$		10 k $\Omega$	
DC Ranges:	300 mVs	30 mVs	30 mVs	3 mVs
DC Resolution:	0.001 mVs	0.0005 mVs	0.0005 mVs	0.0005 mVs

DC Accuracy: Offset:  $\pm 10$   $\mu$ Vs  $\pm$ DC Integrator Drift

Gain:  $\pm 0.25\%$  of reading (<10 Vs/s max. rate of change)

DC Minimum  $d\phi/dt$ : 20  $\mu$ Vs/minute

DC Maximum  $d\phi/dt$ : 60 Vs/s

DC Integrator Drift:  $\pm 1$   $\mu$ Vs/minute, 0.0004% FS/minute on 300 mVs range

(100 k $\Omega$  input resistance constant temperature environment)

### DC Peak

DC Peak Display Resolution: 4 $\frac{3}{4}$  digits

DC Peak Integrator Capacitance: 1  $\mu$ F nominal

DC Peak Input Resistance:	100 k $\Omega$		10 k $\Omega$	
DC Peak Ranges:	300 mVs	30 mVs	30 mVs	3 mVs
DC Peak Resolution:	0.01 mVs	0.001 mVs	0.001 mVs	0.001 mVs
DC Peak Min. Reading:	0.05 mVs	0.005 mVs	0.005 mVs	0.005 mVs

DC Peak Accuracy: Offset:  $\pm 100$   $\mu$ Vs  $\pm$ DC Integrator Drift

Gain:  $\pm 5\%$  of reading (<10 Vs/s max. rate of change)

DC Peak Maximum  $d\phi/dt$ : 60 Vs/s

DC Peak Update Rate: May reduce update rate to  $\frac{1}{4}$  normal

### AC

AC Display Resolution: 4 $\frac{3}{4}$  digits

AC Integrator Capacitance: 0.1  $\mu$ F nominal

AC Input Resistance: 100 k $\Omega$

AC Ranges:	30 mVs	3 mVs	300 $\mu$ Vs	30 $\mu$ Vs
AC Resolution:	0.001 mVs	0.0001 mVs	0.01 $\mu$ Vs	0.01 $\mu$ Vs
AC Min. Rdg:	3.000 mVs	0.3000 mVs	30.00 $\mu$ Vs	3.00 $\mu$ Vs

AC Frequency Response: 2 Hz to 50 kHz (see Figure 5-1)

AC Accuracy:  $\pm 1\%$  of reading  $\pm 10$   $\mu$ Vs (10 Hz – 10 kHz sinusoidal)

$\pm 5\%$  of reading:  $\pm 10$   $\mu$ Vs (2 Hz – 50 kHz sinusoidal)

AC Integrator Drift: N/A

### AC Peak

AC Peak Display Resolution: 3 $\frac{3}{4}$  digits

AC Peak Integrator Capacitance: 0.1  $\mu$ F nominal

AC Peak Input Resistance: 100 k $\Omega$

AC Peak Ranges:	30 mVs	3 mVs	300 $\mu$ Vs
AC Peak Resolution:	0.01 mVs	0.001 mVs	1 $\mu$ Vs
AC Peak Min. Reading:	0.01 mVs	0.001 mVs	5 $\mu$ Vs

AC Peak Accuracy:  $\pm 5\%$  of reading  $\pm 10$   $\mu$ Vs (10 Hz – 10 kHz sinusoidal)

$\pm 10\%$  of reading  $\pm 10$   $\mu$ Vs (2 Hz – 50 kHz sinusoidal)

AC Peak Update Rate: May reduce update rate to  $\frac{1}{4}$  normal

### Front Panel

Display Type: Two line by 20 character, vacuum fluorescent display

Display Resolution: To  $\pm 5\frac{1}{4}$  digits

Display Update Rate: 5 readings per second

Display Units: Vs, MxN, WbN, Vs $\phi$ , Mx $\phi$ , Wb $\phi$ , G, T, Wbcm, A, %

Units Multipliers: p, n,  $\mu$ , m, k, M, G

Annunciators:  AC input signal

 DC input signal

 Positive and Negative peaks

 Remote Operation

 Alarm on

Keypad: 21 full travel keys

**Specifications (Continued)**

**Interfaces**

IEEE-488.2 Capabilities: SH1,AH1,T5,L4,SR1,RL1,PP0,DC1,DT0,C0,E1  
 Serial Interface: RS-232C Electrical, DA-9 Connector, 9600 BAUD  
 External Reset Type: Contact Closure

**Alarms**

Number: 2  
 Settings: High and low set point, Inside/Outside, Audible  
 Actuators: Display Annunciator, Beeper, Relays for High, Low, and Middle

**Relays**

Number of Relays: 3  
 Contacts: Normally open (NO), normally closed (NC), and common (C)  
 Contact Rating: 30 VDC at 2 A  
 Operation: Follows high and low alarms. Can be operated manually.  
 Connector: Detachable terminal block

**Monitor Analog Output**

Scale:  $\pm 3V = \pm FS$  on Vs range  
 Accuracy:  $\pm 1\%$  of reading  $\pm 10$  mV, (DC to 10 kHz)  
 $\pm 5\%$  of reading  $\pm 10$  mV, (10 kHz to 50 kHz)  
 Minimum load resistance: 1 k $\Omega$   
 Connector: Detachable terminal block

**Corrected Analog Output**

Scale: User Selected  
 Range:  $\pm 10$  V  
 Resolution: 0.3 mV  
 Accuracy:  $\pm 2.5$  mV  
 Minimum load resistance: 1 k $\Omega$   
 Connector: Detachable terminal block

**General**

Ambient Temperature: 15 – 35 °C at rated accuracy. 5 – 40 °C with reduced accuracy  
 Power Requirement: 100, 120, 220, 240 VAC, +5% -10%, 50 or 60 Hz, 20 watts  
 Size: 217 mm W x 90 mm H x 317 mm D half rack (8.5 x 3.5 x 12.5 inches)  
 Weight: 3 kilograms (6.6 pounds)  
 Approval: CE Mark (consult Lake Shore for availability)

**Ordering Information**

*Part number Description*

Instrument	
480	Fluxmeter

Specify line voltage when ordering

**Instrument Accessories**

RM-1/2	Rack Mount Kit for mounting one 1/2 rack fluxmeter in 482.6 mm rack
RM-2	Rack Mount Kit for mounting two 1/2 rack fluxmeters in 482.6 mm rack
4004	IEEE-488 cable, 1 meter
119-028*	Model 480 User's Manual
106-739*	Terminal Block Mating Connector (8 pin, quantity 2)

**Probes and Coils (ordered separately)**

FNT-6R04-100	Field Probe (100 cm <sup>2</sup> )
FNT-5R04-30	Field Probe (30 cm <sup>2</sup> )
FH-2.5	Helmholtz Coil (2.5 inch I.D.)
FH-6	Helmholtz Coil (6 inch I.D.)
FH-12	Helmholtz Coil (12 inch I.D.)
FCBL-6	User Programmable Cable with PROM (6 feet long)

Custom probes/coils/fixtures available (consult Lake Shore for more information)

\* Accessories/options included with a new Model 480.

### 1.3 SAFETY SUMMARY

Observe these general safety precautions during all phases of instrument operation, service, and repair. Failure to comply with these precautions or with specific warnings elsewhere in this manual violates safety standards of design, manufacture, and intended instrument use. Lake Shore assumes no liability for Customer failure to comply with these requirements.

The Model 480 protects the operator and surrounding area from electric shock or burn, mechanical hazards, excessive temperature, and spread of fire from the instrument. Environmental conditions outside of the conditions below may pose a hazard to the operator and surrounding area.

- Indoor use.
- Altitude to 2,000 meters.
- Temperature for safe operation: 5 °C to 40 °C.
- Maximum relative humidity: 80% for temperature up to 31 °C decreasing linearly to 50% at 40 °C.
- Power supply voltage fluctuations not to exceed ±10% of the nominal voltage.
- Overvoltage category II.
- Pollution degree 2.

**Ground The Instrument.** To minimize shock hazard, connect the instrument chassis and cabinet to an electrical ground. The instrument is equipped with a three-conductor AC power cable. Plug the power cable into an approved three-contact electrical outlet or use a three-contact adapter with the grounding wire (green) firmly connected to an electrical ground (safety ground) at the power outlet. The power jack and mating plug of the power cable meet Underwriters Laboratories (UL) and International Electrotechnical Commission (IEC) safety standards.

**Ventilation.** The instrument has ventilation holes in its top and bottom covers. Do not block these holes when the instrument is turned on.













**Do Not Operate In An Explosive Atmosphere.** Do not operate the instrument in the presence of flammable gases or fumes. Operation of any electrical instrument in such an environment constitutes a definite safety hazard.

**Keep Away From Live Circuits.** Operating personnel must not remove instrument covers. Refer component replacement and internal adjustments to qualified maintenance personnel. Do not replace components with power cable connected. To avoid injuries, always disconnect power and discharge circuits before touching them.

**Do Not Substitute Parts Or Modify Instrument.** Do not install substitute parts or perform any unauthorized modification to the instrument. Return the instrument to an authorized Lake Shore Cryotronics, Inc. representative for service and repair to ensure that safety features are maintained.

**Cleaning.** Do not submerge instrument. Clean only exterior with a damp cloth and mild detergent.

### 1.4 SAFETY SYMBOLS

	Direct current (power line).		Equipment protected throughout by double insulation or reinforced insulation (equivalent to Class II of IEC 536 - see Annex H).
	Alternating current (power line).		Caution: High voltages; danger of electric shock. Background color: Yellow; Symbol and outline: Black.
	Alternating or direct current (power line).		Caution or Warning - See instrument documentation. Background color: Yellow; Symbol and outline: Black.
	Three-phase alternating current (power line).		Fuse.
	Earth (ground) terminal.		
	Protective conductor terminal.		
	Frame or chassis terminal.		
	On (supply).		
	Off (supply).		

## CHAPTER 2

# MAGNETIC MEASUREMENT OVERVIEW

### 2.0 GENERAL

This chapter provides an overview of magnetic measurements relating to the operation of the Lake Shore Model 480 Fluxmeter. Integrating instruments is in Paragraph 2.1; coil characteristics in Paragraph 2.2, flux overview in Paragraph 2.3, flux density overview in Paragraph 2.4, magnetic moment overview in Paragraph 2.5, and magnetic potential overview in Paragraph 2.6.

### 2.1 INTEGRATING INSTRUMENTS

#### 2.1.1 What Is An Integrator?

The output of the integrator in a fluxmeter is proportional to ( $\propto$ ) the voltage at its input as it varies with time. In the most simple example, a voltage of 1 volt (V) present at the input of a fluxmeter for 1 second (s) results in a reading of 1 volt second (V·s). Volt seconds are the primary unit of measurement for an integrator. The product of volts and seconds is the area under the voltage line if it were plotted on a graph against time. When the input voltage changes in an irregular way, integrator output cannot be calculated by simply multiplying voltage and time. The integrator reacts continuously to the changing input to give an accurate area measurement.

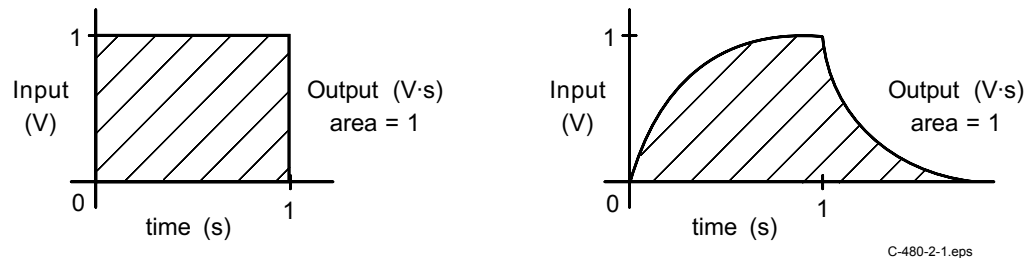

#### 2.1.2 Why Integrators Are Used For Magnetic Measurement

Integrators are used in magnetic measurements because of the physical relationship between coils of wire and magnetic flux ( $\phi$ ). The instantaneous voltage produced across a coil ( $V_{coil}$ ) is proportional to the number of turns in the coil ( $N$ ) times the rate of change in flux ( $d\phi/dt$ ):

$$V_{coil} \propto N \frac{d\phi}{dt}$$

It is inconvenient to use this relationship directly for DC measurements because the voltage disappears as soon as the flux stops changing. The voltage is also proportional to the rate of change in flux and not the total change in flux which is often the desired measurement. If  $V_{coil}$  is integrated to look at the area under  $V_{coil}$  plotted against time, the above problems disappear. The integrator output is proportional to the total change in flux and rate of change does not matter. Expressed mathematically:

$$\int V_{coil} dt \propto N\phi \quad \text{or} \quad \phi \propto \frac{1}{N} \int V_{coil} dt$$

**Why Integrators Are Used For Magnetic Measurement (Continued)**

The total flux change can be measured with a fluxmeter as a coil moves near a magnet or as a magnet moves near a coil.

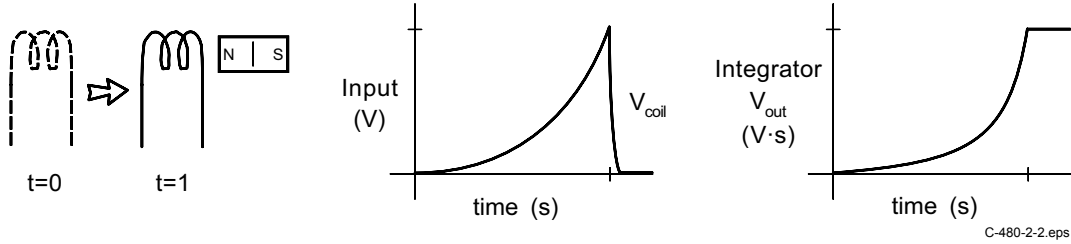

**2.1.3 Important Integrator Characteristics**

Some parameters that describe the integrator in a fluxmeter are familiar like range and resolution. If the measurement range is too small, an over range condition can exist. If the range is too large, there is not enough resolution to make accurate measurements. Available integrator ranges should be taken into account when designing sensing coils. Ranges are often expressed in volt seconds which is the fundamental measurement of the integrator. Range can be expressed in flux units if the number of coil turns is known.

Some characteristics of integrators are not seen in other measurements. Two components dominate the behavior of an integrator, its input resistance ( $R_{in}$ ) and integrating capacitor ( $C_{int}$ ). The expression for a voltage integrator is:

$$V_{out} \propto \frac{1}{R_{in} C_{int}} \int V_{in} dt$$

The product  $R_{in} C_{int}$  is called the integrator time constant, but for practical purposes,  $1/R_{in} C_{int}$  can be considered the integrator gain. A more complete expression for flux is:

$$\phi \propto \frac{1}{NR_{in} C_{int}} \int V_{coil} dt$$

In the ideal case,  $R_{in}$  and  $C_{int}$  could be any value and only their product would matter. In reality there are practical limits to both. Instrument manufacturers optimize the two values for best performance. Many specifications are given based on specific values of  $R_{in}$  and  $C_{int}$ .

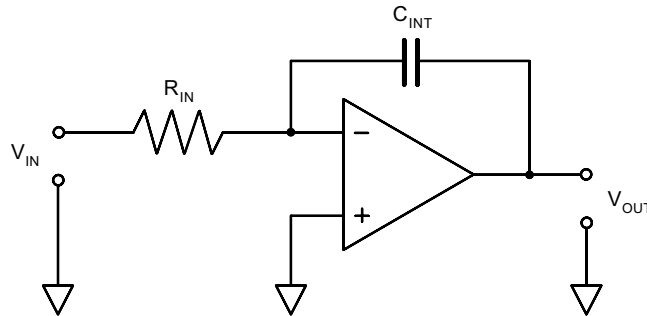

Ideal Operational Amplifier Integrator Circuit

C-480-2-3.eps

For most users, the choice of fluxmeter  $R_{in}$  and  $C_{int}$  has little meaning to their measurement. There are exceptions. The integrator resistance is the sum of input resistance and coil resistance. Coil resistance must be accounted for when it is a meaningful percentage of  $R_{in}$ . Refer to Paragraph 2.2.3 for more details.

**Important Integrator Characteristics (Continued)**

Other integrator characteristics that may affect measurements are drift, maximum input voltage, and maximum and minimum rate of input change. These characteristics are a result of fluxmeter design; the user often has little control. Check specifications carefully before choosing a fluxmeter for any application or designing a coil for a fluxmeter.

**2.1.4 Reducing Integrator Drift**

Drift is the most noticeable and often the largest source of error in integrating fluxmeters. Drift is a slow change in reading when no change in flux exists. It is caused by any small error voltage at the integrator input.

Manufacturers spend significant time and effort reducing the drift in instrument integrators. Component type and value, circuit board layout and manufacturing methods are all optimized to reduce drift. Temperature change contributes so much to drift that critical components are often thermally isolated from other parts of the circuit.

Low drift is a result of good fluxmeter design, but users can do things to maintain low drift:

1. Use the instrument on the range specified for lowest drift.
2. Attach sensing coil leads tightly and avoid unnecessary junctions or connections.
3. Keep drafts or other temperature changes away from the coil lead contacts.
4. Allow the instrument to warm up before drift is adjusted and adjust drift as often as practical during use.
5. Reset the integrator often, before every critical measurement if possible.

Some instruments have built in software algorithms that help adjust drift to zero before measurement. Other algorithms work in a different way to cancel drift during measurement. It is important to understand the difference and the affects on measurements.

**2.1.5 Dielectric Absorption**

All capacitors exhibit a characteristic that can be described as a tendency to rebound from any fast change. When capacitors are discharged to zero volts momentarily, a small voltage will rise a few seconds later across the capacitor. Likewise, a rapid charge of a capacitor to some voltage will be followed by a slight reduction of that potential occurring over several seconds. This characteristic is usually referred to as Dielectric Absorption. The effect of dielectric absorption in the Model 480 fluxmeter is a slight reading change over several seconds after a larger reading change. This occurs predictably during reading changes from 0 to some level and more notably occurs when the reading is reset. A reset from a large, full scale reading will show a "creeping up" of the reading for several seconds after the reset. The level of this effect is approximately 0.03% of the reading change. The effect is most noticeable in the first few seconds and stabilizes after 20-30 seconds. For the most accurate reset of larger measurements an initial reset should be followed by a second reset a few seconds later.

As inconvenient as this is, capacitor limitations create this condition and cannot be easily remedied. The capacitor selection for the Model 480 included testing of many vendors and capacitor dielectric types. The selected capacitors offer the best overall characteristics including that of dielectric absorption. It is felt that even though this is certainly a source of error for all analog integrating fluxmeters, the Model 480 is capable of seeing this characteristic with it's increased resolution while others have simply ignored it. During instrument factory calibration readings are taken 1 to 2 seconds after any signal transition. DC Peak, AC and AC Peak readings do not suffer from this anomaly.

### 2.1.6 Analog Versus Digital Integrators

Most of the integrator discussion in this manual is based on analog integrators. Analog integrators are made with analog amplifiers, resistors and capacitors. Digital integrators approximate the action of analog integrators by combining voltage sampling and software integration algorithms. There are advantages and disadvantages to both types of integrators.

The performance of digital circuitry continues to improve and the price continues to decline. There are now few analog functions that cannot be approximated digitally. Digital circuits are generally smaller and have fewer discrete components. Their behavior is more repeatable with fewer calibrations. Digital integration is likely the best choice to integrate predictable and well behaved signals.

Analog circuit technology is not standing still. Fast changing, high voltage, or very low voltage signals are still integrated most accurately with analog integrators. The general purpose Model 480 uses an analog integrator. The instrument must perform well with any type of input signal. The digital circuitry surrounding the analog integrator offers most of the advantages of a fully digital circuit.

### 2.1.7 Fluxmeter Measurements In Magnetizers

Magnet materials such as Alnico and Samarium Cobalt are not permanent magnets until they are conditioned in a magnetizer. The magnetizer produces strong fields by passing current through a coil fixture. The magnetizer and coil fixture are optimized based on the magnet material and shape. If the magnetizing field is not strong enough the magnet will not be fully magnetized.

Best cycle times and coil life are achieved when the magnetizer is operated at the minimum voltage required to attain the needed magnetic field. The Model 480 provides an easy way to measure the peak field when the magnetizer voltage is being determined during initial setup. Peak field is best measured in an empty magnetizer fixture. During production magnetizing fixtures age and it is not uncommon for a coil turn to short. Magnetizer current measurements are not enough to identify many fixture problems. Peak field should be measured periodically as part of a quality control process and to determine the general health of the fixture.

Many users want a way to determine if the Model 480 is fast enough to capture the peak field generated by their magnetizer. The remainder of this section describes how the Model 480 can be used with even the fastest magnetizers if the sense coil is designed properly. Discussion begins with an approximation of the wave shape of the field generated by a magnetizer. The maximum rate of change is then identified and it is shown how that rate of change is the only true limit on peak speed. Finally coil sensitivity is discussed and examples are given of how to determine appropriate area turns of a coil.

#### 2.1.7.1 The Magnetizer Pulse

In many cases the magnetizer current is provided by a quick, high current discharge of a capacitor bank. The shape of the magnetic field during this discharge is shown in the figure below.

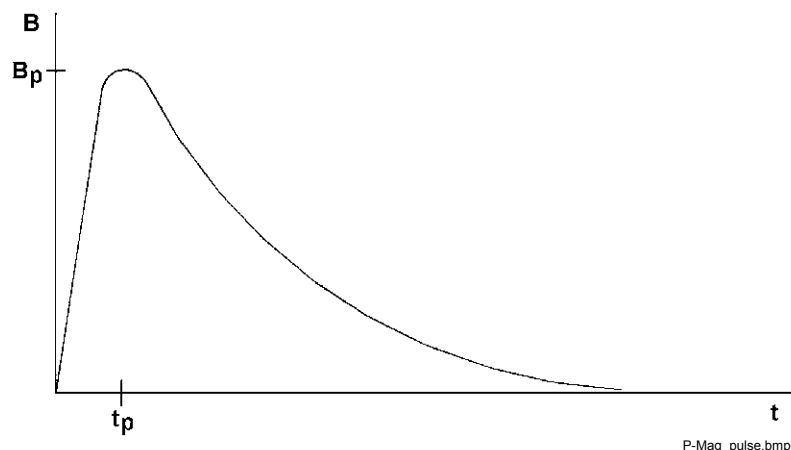

**The Magnetizer Pulse (Continued)**

The time “ $t_p$ ” to reach peak magnetic field “ $B_p$ ” is considered the rise time of the pulse. These are two important parameters to consider when selecting or designing the sense coil for the 480.

**2.1.7.2 Coil Output Voltage Limits**

Because of slew rate requirements and safety considerations, the maximum voltage at the coil output should be limited to 60 volts. The Model 480 Fluxmeter is capable of measuring the fastest of magnetizer pulses, so long as the 60 volt limit is not exceeded. Therefore, the area turns of the coil must be matched to the peak field and rise time of the magnetic field pulse.

The equation for calculating the coil voltage in CGS units is:

$$V = NA \left( \frac{dB}{dt} \right) \times 10^{-8}$$

where V = volts, A = cm<sup>2</sup>, B = gauss, N = number of coil turns, and t = seconds.

The equation for calculating the coil voltage in SI units is:

$$V = NA \left( \frac{dB}{dt} \right)$$

where V = volts, A = meters<sup>2</sup>, B = tesla, N = number of coil turns, and t = seconds.

**2.1.7.3 Calculation of Minimum Rise Time**

What is the fastest pulse allowable? When the area-turns (NA) of the coil and the desired peak field ( $B_p$ ) are known, the above equations can be used to calculate the minimum rise time.

$$t_p = NAB/V \quad (\text{SI units})$$

Calculations of minimum rise times are given for two standard Lake Shore probes.

$$V = 60 \text{ volts and } \text{cm}^2 \times 10^{-4} = \text{meters}^2$$

NA = 30 cm <sup>2</sup>	If $B_p = 3$ tesla, $t_p > 150 \mu\text{s}$ If $B_p = 5$ tesla, $t_p > 250 \mu\text{s}$ If $B_p = 7$ tesla, $t_p > 350 \mu\text{s}$
NA = 100 cm <sup>2</sup>	If $B_p = 3$ tesla, $t_p > 500 \mu\text{s}$ If $B_p = 5$ tesla, $t_p > 833 \mu\text{s}$ If $B_p = 7$ tesla, $t_p > 1200 \mu\text{s}$ (1.2 ms)

**2.1.7.4 Calculation Of Area-Turns**

Often the user will make his own coil to be used with a specific magnetizing fixture. The maximum area-turns (NA) needs to be calculated, to ensure the 60 volt input limit is not exceeded. The equation below can be used.

$$NA < Vt_p/B_p \text{ meters}^2 \quad (\text{SI units})$$

For example, if the rise time  $t_p$  is 5  $\mu\text{s}$  and the peak field  $B_p$  is 3 tesla, then the following is a calculation of the maximum area-turns (NA) to ensure the coil voltage will not exceed 60 volts.

$$NA < (60V) (5 \times 10^{-6} \text{ s}) / 3 \text{ T} = 1 \times 10^{-4} \text{ meter}^2 = 1 \text{ cm}^2$$

### 2.1.8 Making AC Measurements

Traditionally, integrating fluxmeters make DC flux measurements where the measured field changes in a non-periodic way. With only slight modifications to the integrator, a fluxmeter can measure periodic AC fields. AC measurements are useful in measuring stray fields around transformers or the poles of a rotating magnet.

A simple expression for a sinusoidal AC flux ( $\phi(t)$ ) as it varies with time is:

$$\phi(t) = \phi_{\max} \sin(2\pi ft)$$

where  $\phi_{\max}$  is the maximum amplitude of flux,  $f$  is the frequency, and  $t$  is time.

The voltage generated by a sense coil in a field changing this way is proportional to the derivative of the field:

$$V_{\text{coil}} \propto N \frac{d\phi}{dt} \propto N2\pi f \phi_{\max} \cos(2\pi ft)$$

Note that coil voltage amplitude depends on frequency ( $f$ ) and flux amplitude ( $\phi_{\max}$ ).

The integrator in the instrument reverses the action of the coil and removes the direct frequency dependence:

$$V_{\text{out}} \propto \frac{1}{R_{\text{in}} C_{\text{int}}} \int V_{\text{coil}} dt \propto \frac{N2\pi f}{R_{\text{in}} C_{\text{int}}} \int \phi_{\max} \cos(2\pi ft) dt \propto \frac{N}{R_{\text{in}} C_{\text{int}}} \phi_{\max} \sin(2\pi ft)$$

The integrator output voltage can be processed by a peak detector to find  $\phi_{\text{MAX}}$  or through an RMS converter to find the RMS flux value. The relationships hold true for non-sinusoid AC fields also.

The above discussion assumes that the coil inductance and capacitance are small and that the frequency band of the instrument is not exceeded. Refer to Paragraph 2.2.8 for more details.

## 2.2 COIL CHARACTERISTICS

One reason fluxmeters are popular is the low cost and simple construction of sensing coils. Some coils are as simple as a few turns of copper wire. Coil construction gets more complicated to meet special measurement needs. The inclusion of magnetic materials or special geometries can make a coil a specialized measurement tool.

### 2.2.1 Coil Sensitivity

Sensitivity is the instantaneous voltage ( $V_{\text{coil}}$ ) produced for a given rate of change in flux ( $d\phi/dt$ ). As seen in the equation

$$V_{\text{coil}} \propto N \frac{d\phi}{dt}$$

the coil voltage is directly proportional to the number of turns ( $N$ ), as well as the rate of change in flux. Total change in flux can be measured as the fluxmeter integrates the instantaneous voltage over the measurement interval.

The following is an example of coil sensitivity related to a permanent magnet. Consider a permanent magnet has a pole area ( $A$ ) = 1 cm<sup>2</sup> and internal flux density ( $B$ ) of 1000 G. The flux ( $\phi$ ) =  $BA$  = 1,000 Mx. A typical coil of 100 turns ( $N$ ) that fits snugly around the magnet pole generates an integrator output of 1000 Mx times 100 turns =  $10^5$  MxN = 1mV·s as the magnet is moved into the coil. A coil of more turns would give a larger output.

### Coil Sensitivity (Continued)

Number of turns is important to coil design because it determines coil sensitivity. Ideally, increasing the number of turns always improves coil sensitivity, but in the real world, several factors limit the number of turns. The most important are coil size, DC resistance of the wire, and peak output voltage.

It is possible for a coil to be too sensitive. Coils should be designed so the instantaneous coil voltage does not exceed the rated input voltage of the integrator. Magnetizers can create very large instantaneous coil voltages because their flux changes so quickly ( $d\phi/dt$  is large). It is not difficult to calculate the maximum instantaneous coil voltage if the maximum rate of field change is known.

Using the equations:

$$V_{coil} \propto N \frac{d\phi}{dt} \quad \text{and} \quad B = \frac{\phi}{A}$$

gives us

$$V_{coil} \propto NA \frac{dB}{dt}$$

If  $V_{coil}$  is in volts,  $N$  in turns,  $A$  in  $cm^2$ ,  $B$  in gauss, and  $t$  in seconds,  $V_{coil} = NA(dB/dt) 10^{-8}$ . A magnetizer of modest energy can achieve a flux density change ( $dB$ ) of 3 T (30,000 G) in 1 ms ( $dt$ ). If a coil of 1  $cm^2$  area ( $A$ ) and 100 turns ( $N$ ) is in that field, the voltage generated during firing is:

$$V_{coil} = (100 \times 1 cm^2) \times \left( \frac{30,000 G}{0.001 s} \right) \times 10^{-8} = 30 V$$

Note that high energy magnetizers with faster rise times can produce dangerous voltages with many fewer turns.

#### 2.2.2 Coil Size

Application often dictates coil size. Some low field coils may be several feet in diameter to contain enough changing flux for a measurable coil voltage. Coils for high gradient fields are small as possible so the coil area does not exceed the uniform field area. Coil size often limits the number of turns and therefore the sensitivity.

Coils of any length can be used with a fluxmeter, from a single turn to a long solenoid. In practice, the coil should be limited in length so the same flux lines link all turns. Substantial error occurs when the flux lines curve out of the coil and link only part of the turns. The fluxmeter assumes all of the turns see the same flux.

Some coil geometries count on coil length to achieve specific measurement goals. Coil length can help eliminate the effect of field non-uniformity (Paragraph 2.2.6) or measure magnetic potential (Paragraph 2.6).

#### 2.2.3 Coil Resistance

Coil resistance is sometimes overlooked because it does not appear in ideal equations for a coil or integrator, but it can limit sensitivity. Wire does have resistance and with enough turns it can become applicable. Coil resistance must be accounted for when it is a meaningful percentage of the integrator input resistance.

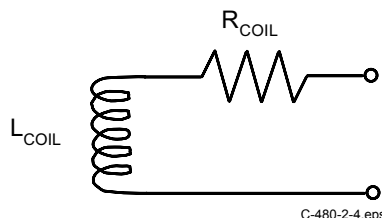

C-480-2-4.eps

**Coil Resistance (Continued)**

The DC resistance of the coil must be added to the input resistance of the integrator to get an accurate volt second reading. The expression for a voltage integrator becomes:

$$V_{out} \propto \frac{1}{(R_{in} + R_{coil}) C_{int}} \int V_{in} dt$$

Manufacturers specify integrator resistance for a fluxmeter typically between 1 k $\Omega$  to 100 k $\Omega$ . Table 2-1 lists examples of copper wire resistance.

**Table 2-1. Examples of Copper Wire Resistance**

AWG Annealed Copper	O.D. inches at 20 °C	Ohms per 1,000 feet at 20 °C
40	0.0031	1079.2
38	0.0040	648.2
36	0.0050	414.8
34	0.0063	261.3
32	0.0080	162.0
30	0.0100	103.7

To calculate the percentage error in reading due to coil resistance:

$$\%Error = \frac{-R_{coil}}{(R_{in} + R_{coil})} \times 100$$

As an example, if  $R_{in} = 100 \text{ k}\Omega$  and  $R_{coil} = 1 \text{ k}\Omega$ , an error of -1% results. If  $R_{in} = 10 \text{ k}\Omega$  and  $R_{coil} = 1 \text{ k}\Omega$ , an error of -9.1% results if coil resistance is not taken into account.

**2.2.4 Coil Temperature Coefficient**

Since coil resistance is temperature dependent, care must be taken when large temperature changes are expected. The temperature coefficient of resistance for copper magnet wire is +0.4%/°C (+0.22%/°F). For example, a temperature increase of 10 °C in a 1000  $\Omega$  coil causes a resistance increase of 40  $\Omega$  to 1040  $\Omega$ . If  $R_{in} = 10 \text{ k}\Omega$ , the attenuation from  $R_{coil}$  in the Paragraph 2.2.3 example changes from -9.1% to -9.43%.

**2.2.5 Coil Orientation**

Coil voltage is related to the number of changing flux lines passing through the center of the coil. The flux measured is a true indication of the number of lines passing through. The angle of the flux lines passing through the coil does not matter, that is not to say that the orientation of a coil to a magnet does not matter. Changing coil orientation relative to a magnet often changes the number of flux lines that pass through the coil. Orient the coil perpendicular to the flux lines for the most repeatable measurements.

### 2.2.6 Field Uniformity

Flux measurement is a true indication of lines of flux passing through a coil. Field uniformity does not affect flux measurement, but other magnetic measurements such as flux density assume uniform flux over the coil area. When measuring flux density in a non-uniform field, the fluxmeter reads the average flux density.

There are some unique coil configurations that help eliminate the effect of field non-uniformity. The length to outer diameter ratio of a coil can be optimized to measure flux density at the center of the coil rather than the average flux density. For more information consult:

Zijlstra, H. *Experimental Methods in Magnetism*, Wiley, pg. 3, 1967.

Herzog & Tischler, *Measurement of Inhomogeneous Magnetic Fields*, Review of Scientific Instruments, Vol. 24, pg. 1000, 1953.

### 2.2.7 Lead Pickup

Loops other than the sensor coil should be eliminated or minimized. Loops in lead wires see changing flux just like a coil. Their voltage is an error added or subtracted from the coil voltage. Twisted leads from the coil to the fluxmeter are recommended to reduce loop area and minimize error voltage.

### 2.2.8 Inductance, Capacitance, and Self Resonance

There are error sources that are only important when making AC or very fast peak DC measurements.

Keep coil inductance ( $L_{coil}$ ) small, or it acts similar to coil resistance and reduces sensitivity. The real impedance of a coil due to inductance is  $2\pi f L_{coil}$ . That value should be small compared to the input resistance of the integrator, or the signal is attenuated. The attenuation changes with frequency because the impedance does. The equation for calculating inductance of an ideal long solenoid is:

$$L_{coil} = \mu_0 N^2 \frac{A}{l}$$

where  $\mu_0 = 4\pi 10^{-7}$  H/m,  $N$  = turns,  $A$  = area in  $m^2$ ,  $l$  = length in m, and  $L_{coil}$  is in henries (H). Equations for flat search and Helmholtz coils are more complicated because there is no simple relationship between inductance and length, but the effects of area and number of turns remain consistent.

There is capacitance between each turn of wire in a coil ( $C_{coil}$ ). Impedance resulting from the capacitance itself is most often negligible at frequencies below 50 kHz. However, the capacitance reacts with the coil inductance to make the coil resonate. Operating anywhere near the coil resonant frequency gives unpredictable results. The frequency of resonance is:

$$\frac{1}{2\pi\sqrt{L_{coil}C_{coil}}}$$

### 2.2.9 Lake Shore Coils and Probes

It may be desirable to purchase pre-fabricated sense coils optimized for Model 480 use. Lake Shore offers search and Helmholtz coils. Dimensions and specifications appear in Chapter 7. They are designed for every day use with well secured windings and strain relief at connection points.

Factory calibration ensures accurate measurements from the start without field calibrating the coil in a magnet standard. They also ensure interchangeability of probes and fluxmeters for reproducible measurements. Lake Shore calibrations use the most accurate standards available. Each coil comes with calibration data that may include number of turns, area, and resistance.

Lake Shore sense coils are very easy to use. Calibrated coil parameters are usually pre-programmed into non-volatile memory in the connector. Users need only plug in the connector, turn the power on, and begin taking measurements.

## 2.3 FLUX OVERVIEW

Scientists envision a magnetic field as lines of flux leaving the north pole of a magnet and returning to the south pole. The symbol for flux is  $\phi$ . A unit of flux is called a line. In the CGS system, one line of flux equals one maxwell (Mx). In the SI system, the flux unit is the weber (Wb), where:

$$1\text{Wb} = 10^8 \text{Mx} = 10^8 \text{lines}.$$

Flux is the basic Model 480 magnetic measurement. All other measurements derive from flux measurement and knowledge of the coil geometry.

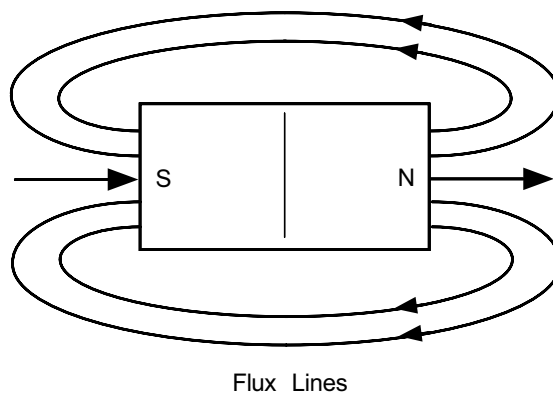

C-480-2-5.eps

Flux is measured to indicate energy transferred by a magnet or the energy capacity of a permanent magnet, to sort magnets, or to determine other magnetic properties such as flux density (Paragraph 2.4).

The most common way to measure flux is with a coil and integrating fluxmeter. Knowing only the number of turns in the coil, the fluxmeter measures flux as it changes. Changing flux generates a voltage in the coil. The coil voltage is integrated by the fluxmeter to show the total change in flux.

## 2.4 FLUX DENSITY OVERVIEW

### 2.4.1 What is Flux Density?

A magnetic field consists of flux lines. Flux density is the number of flux lines passing perpendicular through a plane of unit area (**A**). The symbol for flux density is **B** where  $\mathbf{B} = \phi/\mathbf{A}$ . The CGS system measures flux density in gauss (**G**) where  $1 \text{ G} = 1 \text{ Mx/cm}^2$ . The SI system measures flux density in tesla (**T**) where  $1 \text{ T} = 1 \text{ Wb/m}^2$ .

Flux density is important when magnet systems concentrate flux lines into a specific area like the pole pieces in an electromagnet. Forces generated on current carrying wires like those in a motor armature are proportional to flux density. Saturation of magnetic core material is also a function of flux density.

Flux density is often the desired measurement quantity when using a fluxmeter. In a uniform field, flux density can be calculated by dividing measured flux by the area of the search coil. This can be done with a fluxmeter as long as the lines of flux are perpendicular to the plane of a flat coil or along the axis of a longer coil. Hall effect gaussmeters make similar measurements.

Fluxmeters can also measure flux density inside a piece of magnetic material. In this case coils are wrapped tightly around a material core to ensure the area of the coil is the same as the cross section of the core. Gaussmeters cannot make this type of measurement.

## 2.4.2 How Flux Density (**B**) Differs from Magnetic Field Strength (**H**)

Flux density is often confused with magnetic field strength. Magnetic field strength is a measure of the force producing flux lines. The symbol for magnetic field strength is **H**. In the CGS system, it is measured in oersteds (**Oe**). In the SI system, it is measured in amps per meter (**A/m**):

$$1 \text{ Oe} = 79.58 \text{ A/m}$$

Flux density and magnetic field strength are related by the permeability ( $\mu$ ) of the magnetic medium. **B =  $\mu$ H**. Permeability is a measure of how well a material makes a path for flux lines.

The confusion of flux density and magnetic field strength is also related to permeability. In the CGS system, the permeability of air (of vacuum) is 1. Therefore, **1 G = 1 Oe** or **B = H** in air. Many people incorrectly assume therefore that in the CGS system, **B = H** at all times. Adding to the confusion, in the SI system permeability of air is not 1, so **B** is not equal to **H** even in air.

## 2.5 MAGNETIC MOMENT OVERVIEW

### 2.5.1 What is Magnetic Moment?

Magnetic moment (**m**) measures the magnetic field strength (**H**) produced at points in space by a plane current loop or a magnetized body. The CGS system measures moment in **emu** and defines it as the pole strength of a permanent magnet multiplied by the distance between the poles. This is sometimes called dipole moment (**j = Wb m**). The SI system measures moment in amps times square meters (**Am<sup>2</sup>**) and defines it as the current in a conducting loop times the area of the loop or

$$1 \text{ emu} = 10^{-3} \text{ Am}^2$$

Magnetic moment is measured to determine various performance factors of permanent magnets. For example, magnetization (**M**) can be calculated by dividing magnetic moment by the volume of a magnet.

A Helmholtz coil and fluxmeter provide a measurement proportional to the magnetic moment of a permanent magnet, as defined in the CGS System. If the Helmholtz coil constant is known, magnetic moment can be accurately determined. Uncalibrated coils provide reliable comparative data.

Magnetometers like a vibrating sample magnetometer (VSM) also make moment measurements, but usually of much smaller values.

### 2.5.2 Important Parameters of A Helmholtz Coil

For predictable permanent magnet measurements with a Helmholtz coil, the physical dimensions of the coil must be controlled. A Helmholtz coil is two parallel coils spaced so the average diameter of the coils is twice the distance between their central planes. No dimension of the coil cross section should exceed 10% of the coil diameter. Coil diameter should be three to five times the maximum dimension of the part under evaluation.

An empirically derived calibration constant (**Kh**) in centimeters is often provided with the coil to allow a fluxmeter to operate in **Wb·cm**, a more convenient form of the SI unit **Wb·m**, where:

$$\text{Wb} \cdot \text{m} = \text{Wb} \cdot \text{cm} \times 100$$

### 2.5.3 Helmholtz Coil Constant Determination (For Non-Lake Shore Coils)

To use a Helmholtz coil and the Model 480 Fluxmeter to make magnet moment measurements, a Helmholtz Coil Constant is required. Regretfully, this parameter is rarely available. Either the coil is made in-house or the vendor supplies a coil sensitivity (flux density per current unit) rather than the coil constant needed. Given below in Paragraphs 2.5.3.1 and .2 are methods of measuring values which can be used to calculate the constant. Paragraph 2.5.3.3 gives formulas for calculating the coil constant when coil sensitivity is given.

#### 2.5.3.1 By Measurement of Amperes per Gauss

A gaussmeter and current source are required. In free air, one gauss = one oersted. Directly measure the current required (amperes) to produce a certain magnetic field (gauss = oersted). In the calculation of the coil constant, we have to convert oersteds to amperes/centimeter. The Lake Shore 480 fluxmeter accepts a value for coil constant only in centimeters.

COIL CONSTANT =  $K = I/H = \text{amperes/oersted} = \text{amperes/amperes/cm} = \text{cm (units only)}$

Example: A common Helmholtz coil might require 1 ampere to generate a 30 gauss field.

Thus,  $K = 1 \text{ ampere}/30 \text{ oersteds} = 1 \text{ ampere}/(30 \times 0.796 \text{ A/cm}) = 0.0419 \text{ cm}$

#### 2.5.3.2 By Measurement of Amperes per Tesla

Most of the comments above hold, except that the relationship between flux density (B) and magnetic field strength (H) in the SI system is not as simple as in the cgs system.

$$H = B/\mu_0 \text{ where } \mu_0 = 4\pi \times 10^{-7} \text{ (for H = A/m), or}$$

$$H = B/\mu_0 \text{ where } \mu_0 = 4\pi \times 10^{-5} \text{ (for H = A/cm)}$$

COIL CONSTANT =  $K = I/H = \text{amperes/amperes/cm} = \text{cm (units only)}$

Example: The same coil as above requires 1 ampere to generate a 3 mT (millitesla) field.

Thus,  $H = 0.003/(4\pi \times 10^{-5}) = 23.87 \text{ A/cm}$

$$K = 1 \text{ ampere}/(23.87 \text{ A/cm}) = 0.0419 \text{ cm}$$

#### 2.5.3.3 Conversion of Coil Sensitivity

The coil constant conversion factors can be derived by inverting and using the same math as above.

Coil Sensitivity in gauss per ampere  
 $(1/\text{Sensitivity}) \times 1.256 = K \text{ (cm)}$

Coil Sensitivity in milligauss per ampere  
 $(1/\text{Sensitivity}) \times 1256 = K \text{ (cm)}$

Coil Sensitivity in millitesla per ampere  
 $(1/\text{Sensitivity}) \times 0.1256 = K \text{ (cm)}$

Coil sensitivity in microtesla per ampere  
 $(1/\text{Sensitivity}) \times 125.6 = K \text{ (cm)}$

## 2.6 MAGNETIC POTENTIAL OVERVIEW

### 2.6.1 What is Magnetic Potential?

Magnetic potential (sometimes called magnetostatic potential) is the line integral of magnetizing force between two points in a magnetic field. It is the scalar value analogous to voltage in an electrical circuit. The symbol for magnetic potential is  $U$ . The CGS system measures magnetic potential in gilberts (**Gb**) or oersted times centimeters (**Oe·cm**). The SI system measures it in amps (**A**).

Magnetic potential can be used to derive the internal magnetic field strength (**H**) of a permanent magnet. The difference in magnetic potential between two points, where no electrical current exists, is proportional to magnetic field strength (**H**). With magnetic field strength measured with a potential coil and flux density measured by other means, the second quadrant operating point of the magnet can be determined.

A potential coil with a fluxmeter measures the magnetic potential difference between two points on a permanent magnet. The potential coil is generally a long thin solenoid. The tip of the coil is placed perpendicular to the pole of a magnet with the other end of the coil out near zero field. The difference between readings at the two poles is the magnetic potential difference.

### 2.6.2 Important Parameters of a Potential Coil

It is important that the potential coil length is much larger than its diameter. Coil area and number of turns determine sensitivity. The coil must be much longer than the volume of magnetic field.

An empirically derived calibration constant (**Kp**) in amps per volt seconds (**A/V·s**) is often provided with the coil to allow a fluxmeter to operate in the SI unit of amps.

This Page Intentionally Left Blank

# CHAPTER 3

## INSTRUMENT SETUP

### 3.0 GENERAL

This chapter provides setup information for the Lake Shore Model 480 Fluxmeter. A general layout for the Model 480 rear panel and information on how to make line power, coil, probe, and terminal block connections to the Model 480 are provided. If you want to experiment with the various software settings covered in the next chapter before doing a complete hardware setup, the Model 480 may be operated with only the line power connected (i.e., no coil, probe, or terminal block connections).

**CAUTION:** Before plugging in the Model 480 and turning it on, read about line voltage settings in Paragraph 3.3. An improper line voltage setting may damage the Model 480. Check it carefully before powering the instrument for the first time.

This chapter covers receiving the Model 480 in Paragraph 3.1, rear panel control definitions in Paragraph 3.2, power line input assembly in Paragraph 3.3, coil input connections in Paragraph 3.4, probe input connection in Paragraph 3.5, and terminal block in Paragraph 3.6.

### 3.1 RECEIVING THE MODEL 480

This section covers inspection and unpacking in Paragraph 3.1.1 and repackaging for shipment in Paragraph 3.1.2.

#### 3.1.1 Inspection and Unpacking

Inspect shipping containers for external damage. Make all claims for damage (apparent or concealed) or partial loss of shipment in writing to Lake Shore within five (5) days from receipt of goods. If damage or loss is apparent, please notify the shipping agent immediately.

Use the packing list included with the instrument to verify receipt of the instrument, probe and/or coil, accessories, and manual. Inspect for damage. Inventory all components supplied before discarding any shipping materials. If there is freight damage to the instrument, file proper claims promptly with the carrier and insurance company and notify Lake Shore. Notify Lake Shore immediately of any missing parts. Lake Shore cannot be responsible for any missing parts unless notified within 60 days of shipment. Refer to the standard Lake Shore Warranty on the A Page (behind the title page).

#### 3.1.2 Repackaging For Shipment

To return the Model 480, probe, coil, or accessories for repair, replacement, or recalibration, obtain a Return Goods Authorization (RGA) number from Technical Service in the United States, or from the authorized sales/service representative from which the product was purchased. Instruments may not be accepted without a RGA number. When returning an instrument for service, Lake Shore must have the following information before attempting any repair.

1. Instrument model and serial number.
2. User name, company, address, and phone number.
3. Malfunction symptoms.
4. Description of system.
5. Returned Goods Authorization (RGA) number.

Wrap instrument in a protective bag and use original spacers to protect controls. Repack the system in the Lake Shore shipping carton (if available) and seal it with strong paper or nylon tape. Affix shipping labels and FRAGILE warnings. Write the RGA number on the outside of the shipping container or on the packing slip.

### 3.2 REAR PANEL DEFINITION

**CAUTION:** Verify AC Line Voltage shown in the fuse holder window is appropriate for the intended AC power input. Also remove and verify the proper fuse is installed before plugging in and turning on the instrument.

**CAUTION:** Always turn off the instrument before making any rear panel connections. This is especially critical when making probe to instrument connections.

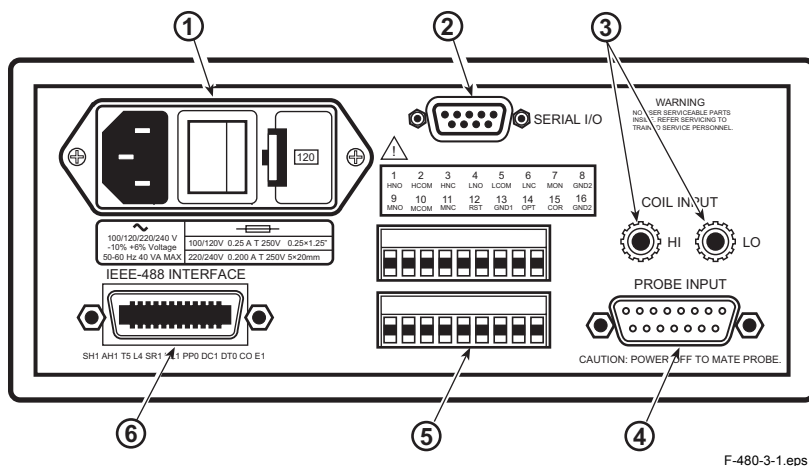

		Description	Pin Definition
①	Line Input Assembly	Paragraph 3.3	Figure 3-2
②	SERIAL I/O Connector	Paragraph 6.2	Figure 8-5
③	COIL INPUT Banana Jacks	Paragraph 3.4	Figure 8-2
④	PROBE INPUT Connector	Paragraph 3.5	Figure 8-3
⑤	Terminal Block	Paragraph 3.6	Figure 8-4
⑥	IEEE-488 INTERFACE Connector	Paragraph 6.1	Figure 8-6

**Figure 3-1. Model 480 Rear Panel**

### 3.3 LINE INPUT ASSEMBLY

This section covers line voltage and fuse verification in Paragraph 3.3.1, power cord in Paragraph 3.3.2, and power switch in Paragraph 3.3.3.

#### 3.3.1 Line Voltage and Fuse Verification

To verify proper line voltage selection look at the indicator in the window of the line input assembly. Line voltage should be in the range shown in the specifications listed on the back of the instrument. See Figure 3-2. If not, change the line voltage selector per instructions in Paragraph 8.3. The fuse must be removed to verify its value, refer to the procedure in Paragraph 8.4. Use slow-blow fuses of the value specified on back of the instrument.

#### 3.3.2 Power Cord

The Model 480 includes a three-conductor power cord. Line voltage is present across the outer two conductors. The center conductor is a safety ground and connects to the instrument metal chassis. For safety, plug the cord into a properly grounded three-pronged receptacle.

#### 3.3.3 Power Switch

The power switch turns the instrument On and Off and is located in the line input assembly on the instrument rear. When I is raised, the instrument is On. When **O** is raised, the instrument is Off.

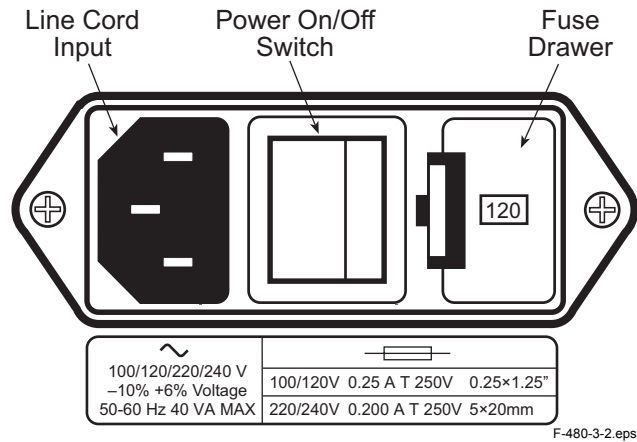

Figure 3-2. Line Input Assembly

### 3.4 COIL INPUT CONNECTION

**WARNING:** Many coils used with the fluxmeter have conductive parts. Never probe near exposed live voltage. Personal injury and damage to the instrument may result.

**CAUTION:** Always turn off the instrument before making any rear panel Coil Input connections.

Connect sensing coils directly to the Model 480 rear panel binding posts. The binding posts accept bare lead wires or a dual banana plug. Ensure that connections are tight. Loose wires can create unpredictable measurements. Turn the instrument off before attaching coil wires. See Figure 8-2 for pin definitions.

After connecting the coil, refer to Paragraph 5.4 to enter the coil parameters into the instrument.

### 3.5 PROBE INPUT CONNECTION

**WARNING:** Many probes used with the fluxmeter have conductive parts. Never probe near exposed live voltage. Personal injury and damage to the instrument may result.

**CAUTION:** Always turn off the instrument before making any rear panel Probe Input connections.

Lake Shore coils and probes plug into the 15-pin D-type connector on the Model 480 rear panel. Turn the instrument off before attaching a probe. See Figure 8-3 for pin definitions.

When power is turned on, the instrument reads coil parameters from probe memory. The probe is ready to use. No parameters need to be entered into the Model 480. Drift must still be adjusted as described in Paragraph 5.9.

#### 3.5.1 Attachment To A Non-Lake Shore Coil

The FCBL-6 has a 15 pin D-connector on one end for direct attachment to the PROBE INPUT on the back panel of the Model 480 Fluxmeter. Two tinned wires are provided for the coil connection. The coil leads may be soldered directly to these wires. If the coil has a banana receptacle on it, a screw-contact banana plug is supplied with the FCBL-6 for attachment.

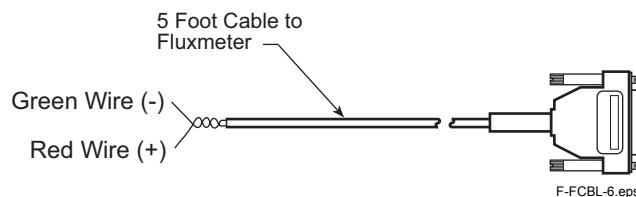

Figure 3-3. Model FCBL-6 User Programmable Cable Accessory

**Attachment to a Non-Lake Shore Coil (Continued)**

If the polarity of the signal from the coil is known, the red wire should be attached to the lead supplying the positive voltage under normal usage. The green wire is at ground potential on the Model 480. If the polarity is not known, just make the connection, run a test, and reverse the lead attachment if a different polarity reading is desired.

**Caution:** The customer coil should be isolated from all line voltages (or voltages referenced to earth ground). *If not, damage to the Model 480 Fluxmeter is almost a certainty.*

Once connections are made, refer to Paragraph 5.6.2 for instructions for storing probe parameters in the internal EPROM.

**3.6 TERMINAL BLOCK**

The Model 480 rear panel terminal block contains signals for alarms, analog output, and external reset. The terminal block connectors are detachable. Remove either the top or bottom terminal block from the instrument for convenient wire installation. Up to 12 AWG stranded copper wire may be used, though smaller wire is suitable for most applications.

**CAUTION:** Always turn off the instrument before making any rear panel terminal block connections.

Terminal	Description	Terminal	Description
1	High Alarm N.O.	9	Middle Alarm N.O.
2	High Alarm COM	10	Middle Alarm COM
3	High Alarm N.C.	11	Middle Alarm N.C.
4	Low Alarm N.O.	12	External Reset
5	Low Alarm COM	13	Ground for Ext. Reset or Optional Input
6	Low Alarm N.C.	14	Optional Input
7	Monitor Output – Signal	15	Corrected Output – Signal
8	Monitor Output – Ground	16	Corrected Output – Ground

**3.6.1 Alarm Relay Connection**

The Model 480 has alarm relays: high, middle, and low. The terminal block has normally open (N.O.), normally closed (N.C.), and common contacts (COM) for each relay. The instrument provides no power through the relays; they open and close as switches relative to their common contact. The contacts are rated at 30 VDC at 2 A. Refer to Paragraph 5.14 for alarm operation.

**3.6.2 Analog Output Connections**

The Model 480 has two analog outputs: corrected and monitor. The terminal block has a signal and ground contact for each analog output. The voltage outputs are short-circuit protected, but loads of 1 k $\Omega$  or greater are required for specified operation. The operation of the two outputs is different. Refer to Paragraph 5.15.1 for corrected output and Paragraph 5.15.2 for monitor output operation.

**3.6.3 External Reset Connections**

The Model 480 terminal block has connections for external reset. With this feature, a foot pedal or Programmable Logic Controller (PLC) can be used to start a new measurement cycle. Refer to Paragraph 5.16 for external reset operation. The External Reset is TTL compatible and a logic low will activate a reset. The signal is internally pulled up to allow operation with a simple switch closure between Pins 12 and 13.

**3.6.4 Optional Input Connection**

The Model 480 terminal block has a connection for an optional logic input. It is commonly used to monitor status of a thermostat or proximity switch. The Model 480 monitors the logic level of this input which can then be read over computer interface. The input is TTL compatible. A logic low will produce a 0 interface response and a logic high will produce a 1 interface response. The signal is internally pulled up to allow operation with a simple switch closure between Pins 14 and 13.

# CHAPTER 4

## BASIC OPERATION

### 4.0 GENERAL

This chapter provides basic operating instructions for the Lake Shore Model 480 Fluxmeter. Turning on power is described in Paragraph 4.1; display definition in Paragraph 4.2, reading format in Paragraph 4.3, keypad definition in Paragraph 4.4, general keypad operation in Paragraph 4.5, and quick start procedures in Paragraph 4.6.

### 4.1 TURNING ON POWER

After line voltage verification (Paragraph 3.3), plug the instrument end of the line cord (included with the connector kit) into the line cord input on the instrument rear. Plug the other end of the line cord into a properly grounded, three-prong receptacle. Turn the power switch, located next to the line cord receptacle, to ON (I). The instrument begins the power-up sequence detailed as follows.

1. The instrument alarm beeper beeps once.
2. The display shows a message with the instrument model number.
3. The display clears.
4. The normal reading display appears.

An alarm annunciator, beeper, or overload (OL) indicator are not cause for immediate concern. These conditions will likely be corrected during instrument setup.

An incomplete sequence, error message (Paragraph 8.8), or blank display may indicate a problem. Check all connections and line input power (refer to Chapter 8). If problems persist, call Lake Shore.

### 4.2 DISPLAY DEFINITION

The Model 480 has a 2-line by 20-character vacuum fluorescent display. During normal operation the instrument displays both readings and annunciators. The top line of the display shows the DC, DC Peak, AC, or AC Peak reading value followed by the prefix and selected units. In dual peak mode, the top line shows the positive peak and the bottom line the negative peak. Annunciators follow to the right of the reading. When changing settings with the keypad, display messages prompt the user with brief instructions.

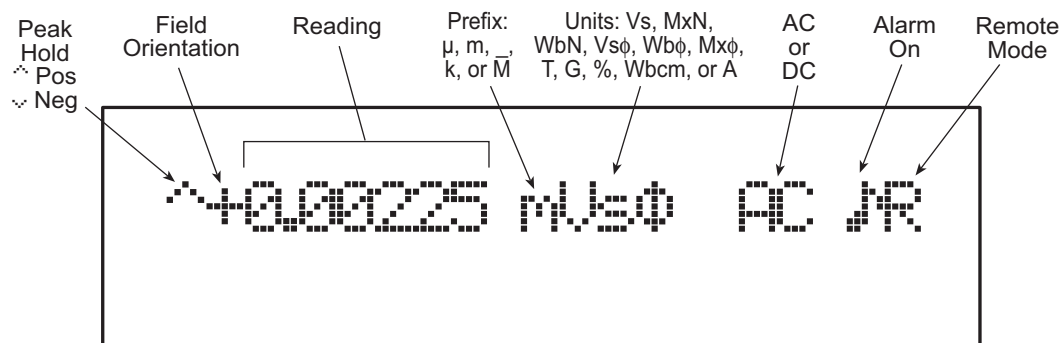

F-480-4-1.eps

Figure 4-1. Model 480 Normal Display Definition

### 4.3 READING FORMAT

The fundamental measurement units of the Model 480 are volt seconds (V·s); therefore many Model 480 specifications appear in that unit. With the input of appropriate coil parameters, the user may set the instrument to display in any of 11 magnetic units. Reading range and display resolution are based on coil parameters and units chosen.

When reading range is chosen, the setting screen indicates the full scale range and resolution for the given coil and units. During operation, readings display in the resolution indicated when range is selected.

A plus or minus sign, up to six digits, a decimal point and appropriate prefix for each reading value. If more than one zero leads the decimal point, the zero does not display and digits are not added to increase resolution.

### 4.4 KEYPAD DEFINITION

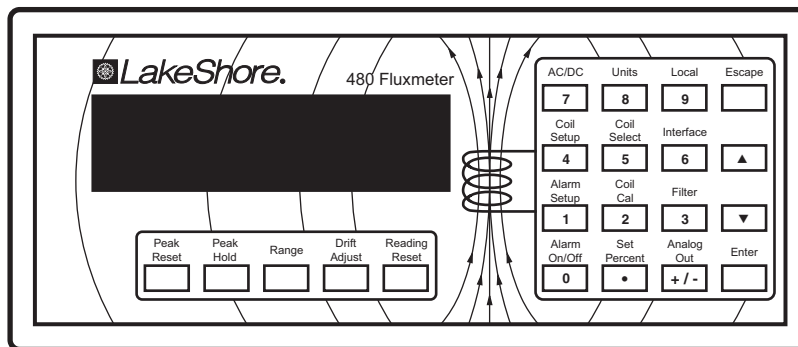

F-480-4-2.eps

**Figure 4-2. Model 480 Front Panel**

- Peak Reset:** Resets Peak Hold hardware and peak reading stored in software. Zeros the display reading. Key is disabled if Peak Hold is turned off.
- Peak Hold:** Turns Peak Hold feature ON or OFF. Peak Hold can be turned on for any units and for DC and AC input. Press and hold to select Peak Mode.
- Range:** Selects the range of input signal. The ranges are fixed in volt-second units but all other ranges depend on coil characteristics.
- Drift Adjust:** Selects one of three integrator drift adjustments (Auto, DriftTrak, and Manual). Press and hold to select threshold for DriftTrak.
- Reading Reset:** Resets the analog integrator and zeros the display reading. Key is disabled when in AC mode.
- AC/DC:** Selects AC or DC signal measurements. In AC mode, the integrator is modified slightly to reject the DC portion of the input signal.
- Units:** Selects one of several measurement units. Accurate measurements require knowledge of the attached coil. Lake Shore probes include all coil information necessary for operation.
- Coil Setup:** Allows users to enter coil parameters for their own coils. Press and hold to select 0  $\Omega$  input resistance. Lake Shore probes include all coil information necessary for operation.
- Coil Select:** Selects 1 of up to 10 coil parameter sets previously stored by the user. Each set may include a value of every coil parameter. Press and hold to store user-entered coil parameter sets.

**KEYPAD DEFINITION (Continued)**

<b>Coil Cal:</b>	Calibrates a users coil with a standard magnet or other known magnetic environment.
<b>Set Percent:</b>	Assigns a scale factor to enable readings in percent units. Press and hold to view or manually set the percent scale factor.
<b>Alarm Setup:</b>	Configures alarm feature for the display and alarm relays.
<b>Alarm On/Off:</b>	Turns alarm feature On or Off.
<b>Local:</b>	Returns instrument to local operation after the IEEE-488 interface has put it in remote mode.
<b>Interface:</b>	Selects the IEEE-488 address and terminators and serial interface baud rate.
<b>Filter:</b>	Configures the display filter which averages readings so environmental noise does not show up on the display. Press and hold to select DC resolution.
<b>Analog Out:</b>	Selects corrected analog output operating mode. There is no user control of monitor output.
<b>Escape:</b>	Terminates a setting function without changing the existing parameter value. Press and hold to reset instrument to default values.
<b>Up Arrow:</b>	Chooses between parameter values during setting operations.
<b>Down Arrow:</b>	Chooses between parameter values during setting operations.
<b>Enter:</b>	Completes setting functions and returns to normal operation. Press and hold to lock or unlock keypad.

**4.5 GENERAL KEYPAD OPERATION**

There are three basic keypad operations:

- 1. Direct Operation:** The key function occurs upon pressing the key. **Peak Reset, Peak Hold, Reading Reset, AC/DC, Local,** and **Alarm On/Off** operate directly when the key is pressed.
- 2. Setting Selection:** Users select from a list of settings. **Range, Drift Adjust, Units, Coil Select, Address, Alarm Setup,** and **Baud** display setting options when pressed. Use the up and down arrow keys as appropriate, then press **Enter** to accept the change or **Escape** to return to the old selection.
- 3. Data Entry:** Users enter numeric data with the data entry keys. Data entry keys include numbered keys, the positive/negative sign (+/-) key, and the decimal point (.) key. The **Coil Setup, Alarm Setup, Coil Cal, Set Percent,** and **Analog Out** keys use data entry.

Use the data entry keys to enter the number value, then press the **Enter** key to accept the new data and advance to the prefix field. Use the **▲** or **▼** keys to select the appropriate prefix and press the **Enter** key again to complete the operation. Press the **Escape** key any time before the operation is complete to return to the old value.

Units prefixes of  $\mu$ , m, \_ (no prefix), k, or M are allowed for most coil parameters and field settings. Not all prefixes make sense for every parameter, but they are left active to ensure the most flexibility for the user. If it is unclear which prefix to use, set the prefix to \_ for no prefix, and the instrument unit shown on the setting screen will be used.

## 4.6 QUICK START PROCEDURES

The quick start procedures steps the user through DC measurements with a typical probe (or coil) and permanent magnet. These procedures enable a user new to the Model 480 to verify the operation of the instrument. Integrator measurement is detailed in Paragraph 4.6.1, flux measurement in Paragraph 4.6.2, flux density measurement in Paragraph 4.6.3, moment measurement in Paragraph 4.6.4, and potential measurement in Paragraph 4.6.5.

### 4.6.1 DC Integrator Measurement In Units of V·s, WbN, or MxN

Use the following procedure to take an integrator measurement.

1. Ensure power is turned Off (O).

**CAUTION:** Always turn off power to the Fluxmeter before making any rear panel PROBE INPUT or COIL INPUT connections.

2. Attach the probe (or coil) to rear of the Fluxmeter. Refer to Paragraph 3.4 for COIL INPUT and Paragraph 3.5 for PROBE INPUT connection instructions.
3. Turn power On (I).
4. Press the **Units** key. For this procedure, we will use Maxwell turns (MxN). Press the ▲ or ▼ keys until "Flux Turns: MxN" is displayed on the screen, then press the **Enter** key. A quick message that details which input parameters are necessary to perform calculations in the units you have selected will appear then disappear.
5. Press the **Coil Setup** key. For this procedure, we will assume an Input Resistance of 100 k $\Omega$ . Press the ▲ or ▼ keys until "Input R: 100k $\Omega$ " is displayed on the screen, press the **Enter** key, then the **Escape** key.
6. If the coil resistance is less than 100  $\Omega$  or is unknown, the default value of 0  $\Omega$  is acceptable and you may skip this step. Otherwise, press the **Coil Setup** key. Press the **Enter** key until "Enter Coil R" is displayed. Use the numeric keypad to enter the coil resistance, then press the **Enter** key. The cursor will jump to a space before the  $\Omega$  symbol. Use the ▲ or ▼ keys to select prefix "\_" for  $\Omega$  or "k" for k $\Omega$ . Press the **Enter** key, then the **Escape** key.

**NOTE:** All the other settings (Turns, Area•Turns, etc.) are ignored when using integrator units.

7. Press the **AC/DC** key until "DC" is displayed on the screen.
8. Press the **Peak Hold** key until "Peak Hold Off" is displayed on the screen.
9. Press the **Range** key. Use the ▲ or ▼ keys to select the range appropriate to your measurement.
10. Press the **Reading Reset** key.
11. If the instrument has just been turned on, allow it to warm up for at least 10 minutes before proceeding. Otherwise, proceed to Step 12.
12. Press the **Drift Adjust** key. Use the ▲ or ▼ keys until "Begin Auto Adjust" is displayed. Press the **Enter** key. You will see the following message: "\*ADJUSTING DRIFT\* For 25 seconds".
13. Make the test measurement.
14. If the reading appears to be drifting, refer to the Drift Adjust discussion in Paragraph 5.9.

#### 4.6.2 DC Flux Measurement In Units of $V \cdot s/\phi$ , $Mx$ , or $Wb$

Use the following procedure to take a flux measurement.

1. Ensure power is turned Off (O).

**CAUTION:** Always turn off power to the Fluxmeter before making any rear panel PROBE INPUT or COIL INPUT connections.

2. Attach the probe (or coil) to rear of the Fluxmeter. Refer to Paragraph 3.4 for COIL INPUT and Paragraph 3.5 for PROBE INPUT connection instructions.
3. Turn power On (I).
4. Press the **Units** key. For this procedure, we will use Webers (Wb). Press the **▲** or **▼** keys until "Flux ( $\phi$ ):  $Wb\phi$ " is displayed on the screen, then press the **Enter** key. A quick message that details which input parameters are necessary to perform calculations in the units you have selected will appear then disappear.
5. Press the **Coil Setup** key. For this procedure, we will assume an Input Resistance of 100 k $\Omega$ . Press the **▲** or **▼** keys until "Input R: 100k $\Omega$ " is displayed on the screen, press the **Enter** key, then the **Escape** key.
6. If the coil resistance is less than 100  $\Omega$  or is unknown, the default value of 0  $\Omega$  is acceptable and you may skip this step. Otherwise, press the **Coil Setup** key. Press the **Enter** key until "Enter coil R" is displayed. Use the numeric keypad to enter the coil resistance, then press the **Enter** key. The cursor will jump to a space before the  $\Omega$  symbol. Use the **▲** or **▼** keys to select prefix "\_" for  $\Omega$  or "k" for k $\Omega$ . Press the **Enter** key, then the **Escape** key.
7. Press the **Coil Setup** key. Press the **Enter** key until "Enter Turns" is displayed. Use the numeric keypad to enter the number of turns, then press the **Enter** key. The cursor will jump to a space before Turns. Use the **▲** or **▼** keys to select prefix  $\mu$ , m, \_, k, or M. Press the **Enter** key, then the **Escape** key.

**NOTE:** All other settings (Area•Turns, Helmholtz Constant, etc.) are ignored when using flux units.

8. Press the **AC/DC** key until "DC" is displayed on the screen.
9. Press the **Peak Hold** key until "Peak Hold Off" is displayed on the screen.
10. Press the **Range** key. Use the **▲** or **▼** keys to select the range appropriate to your measurement.
11. Press the **Reading Reset** key.
12. If the instrument has just been turned on, allow it to warm up for at least 10 minutes before proceeding. Otherwise, proceed to Step 13.
13. Press the **Drift Adjust** key. Use the **▲** or **▼** keys until "Begin Auto Adjust" is displayed. Press the **Enter** key. You will see the following message: "\*ADJUSTING DRIFT\* For 25 Seconds".
14. Make the test measurement.
15. If the reading appears to be drifting, refer to the Drift Adjust discussion in Paragraph 5.9.

### 4.6.3 DC Flux Density Measurement In Units of G or T

Use the following procedure to take a flux density measurement.

1. Ensure power is turned Off (O).

**CAUTION:** Always turn off power to the Fluxmeter before making any rear panel PROBE INPUT or COIL INPUT connections.

2. Attach the probe (or coil) to rear of the Fluxmeter. Refer to Paragraph 3.4 for COIL INPUT and Paragraph 3.5 for PROBE INPUT connection instructions.
3. Turn power On (I).
4. Press the **Units** key. For this procedure, we will use gauss (G). Press the ▲ or ▼ keys until "Flux Density: G" is displayed on the screen, then press the **Enter** key. A quick message that details which input parameters are necessary to perform calculations in the units you have selected will appear then disappear.
5. Press the **Coil Setup** key. For this procedure, we will assume an Input Resistance of 100 k $\Omega$ . Press the ▲ or ▼ keys until "Input R: 100k $\Omega$ " is displayed on the screen, press the **Enter** key, then the **Escape** key.
6. If the coil resistance is less than 100  $\Omega$  or is unknown, the default value of 0  $\Omega$  is acceptable and you may skip this step. Otherwise, press the **Coil Setup** key. Press the **Enter** key until "Enter Coil R" is displayed. Use the numeric keypad to enter the coil resistance, then press the **Enter** key. The cursor will jump to a space before the  $\Omega$  symbol. Use the ▲ or ▼ keys to select prefix "\_" for  $\Omega$  or "k" for k $\Omega$ . Press the **Enter** key, then the **Escape** key.
7. Press the **Coil Setup** key. Press the **Enter** key until "Enter Area•Turns" is displayed. Use the numeric keypad to enter the area turns, then press the **Enter** key. The cursor will jump to a space before  $\text{cm}^2$ . Use the ▲ or ▼ keys to select prefix "\_" Press the **Enter** key, then the **Escape** key.  
**NOTE:** All the other settings (Helmholtz Constant, etc.) are ignored when using flux density units.
8. Press the **AC/DC** key until "DC" is displayed on the screen.
9. Press the **Peak Hold** key until "Peak Hold Off" is displayed on the screen.
10. Press the **Range** key. Use the ▲ or ▼ keys to select the range appropriate to your measurement.
11. Press the **Reading Reset** key.
12. If the instrument has just been turned on, allow it to warm up for at least 10 minutes before proceeding. Otherwise, proceed to Step 13.
13. Press the **Drift Adjust** key. Use the ▲ or ▼ keys until "Begin Auto Adjust" is displayed. Press the **Enter** key. You will see the following message: "\*ADJUSTING DRIFT\* For 25 Seconds".
14. Make the test measurement.
15. If the reading appears to be drifting, refer to the Drift Adjust discussion in Paragraph 5.9.

#### 4.6.4 Moment Measurement In Unit of Wbcm

Use the following procedure to take a moment measurement.

1. Ensure power is turned Off (O).

**CAUTION:** Always turn off power to the Fluxmeter before making any rear panel PROBE INPUT or COIL INPUT connections.

2. Attach the Helmholtz coil to rear of the Fluxmeter. Refer to Paragraph 3.4 for COIL INPUT and Paragraph 3.5 for PROBE INPUT connection instructions.
3. Turn power On (I).
4. Press the **Units** key. Moment measurements are done in the unit of Webers per centimeter (Wbcm). Press the **▲** or **▼** keys until "**Moment : Wbcm**" is displayed on the screen, then press the **Enter** key. A quick message that details which input parameters are necessary to perform calculations in the units you have selected will appear then disappear.
5. Press the **Coil Setup** key. For this procedure, we will assume an Input Resistance of 100 k $\Omega$ . Press the **▲** or **▼** keys until "**Input R: 100k $\Omega$** " is displayed on the screen, press the **Enter** key, then the **Escape** key.
6. If the coil resistance is less than 100  $\Omega$  or is unknown, the default value of 0  $\Omega$  is acceptable and you may skip this step. Otherwise, press the **Coil Setup** key. Press the **Enter** key until "**Enter Coil R**" is displayed. Use the numeric keypad to enter the coil resistance, then press the **Enter** key. The cursor will jump to a space before the  $\Omega$  symbol. Use the **▲** or **▼** keys to select prefix "**\_**" for  $\Omega$  or "**k**" for k $\Omega$ . Press the **Enter** key, then the **Escape** key.
7. Press the **Coil Setup** key. Press the **Enter** key until "**Helmholtz Constant**" is displayed. Use the numeric keypad to enter the Helmholtz constant, then press the **Enter** key. The cursor will jump to a space before **cm**. Use the **▲** or **▼** keys to select prefix "**\_**". Press the **Enter** key, then the **Escape** key.

**NOTE:** All the other settings (Turns, Area•Turns, etc.) are ignored when using moment units.

8. Press the **AC/DC** key until "**DC**" is displayed on the screen.
9. Press the **Peak Hold** key until "**Peak Hold Off**" is displayed on the screen.
10. Press the **Range** key. Use the **▲** or **▼** keys to select the range appropriate to your measurement.
11. Press the **Reading Reset** key.
12. If the instrument has just been turned on, allow it to warm up for at least 10 minutes before proceeding. Otherwise, proceed to Step 13.
13. Press the **Drift Adjust** key. Use the **▲** or **▼** keys until "**Begin Auto Adjust**" is displayed. Press the **Enter** key. You will see the following message: "**\*ADJUSTING DRIFT\* For 25 Seconds**".
14. Make the test measurement.
15. If the reading appears to be drifting, refer to the Drift Adjust discussion in Paragraph 5.9.

#### 4.6.5 Potential Measurement In Unit of A

Use the following procedure to take a potential measurement.

1. Ensure power is turned Off (O).

**CAUTION:** Always turn off power to the Fluxmeter before making any rear panel PROBE INPUT or COIL INPUT connections.

2. Attach the probe (or coil) to rear of the Fluxmeter. Refer to Paragraph 3.4 for COIL INPUT and Paragraph 3.5 for PROBE INPUT connection instructions.
3. Turn power On (I).
4. Press the **Units** key. Potential measurements are done in the unit of Amperes (A). Press the **▲** or **▼** keys until "Potential: A" is displayed on the screen, then press the **Enter** key. A quick message that details which input parameters are necessary to perform calculations in the units you have selected will appear then disappear.
5. Press the **Coil Setup** key. For this procedure, we will assume an Input Resistance of 100 k $\Omega$ . Press the **▲** or **▼** keys until "Input R: 100k $\Omega$ " is displayed on the screen, press the **Enter** key, then the **Escape** key.
6. If the coil resistance is less than 100  $\Omega$  or is unknown, the default value of 0  $\Omega$  is acceptable and you may skip this step. Otherwise, press the **Coil Setup** key. Press the **Enter** key until "Enter Coil R" is displayed. Use the numeric keypad to enter the coil resistance, then press the **Enter** key. The cursor will jump to a space before the  $\Omega$  symbol. Use the **▲** or **▼** keys to select prefix "\_" for  $\Omega$  or "k" for k $\Omega$ . Press the **Enter** key, then the **Escape** key.
7. Press the **Coil Setup** key. Press the **Enter** key until "Potential Constant" is displayed. Use the numeric keypad to enter the Potential constant, then press the **Enter** key. The cursor will jump to a space before A/Vs. Use the **▲** or **▼** keys to select prefix "\_" Press the **Enter** key, then the **Escape** key.

**NOTE:** All the other settings (Turns, Area•Turns, etc.) are ignored when using potential units.

8. Press the **AC/DC** key until "DC" is displayed on the screen.
9. Press the **Peak Hold** key until "Peak Hold Off" is displayed on the screen.
10. Press the **Range** key. Use the **▲** or **▼** keys to select the range appropriate to your measurement.
11. Press the **Reading Reset** key.
12. If the instrument has just been turned on, allow it to warm up for at least 10 minutes before proceeding. Otherwise, proceed to Step 13.
13. Press the **Drift Adjust** key. Use the **▲** or **▼** keys until "Begin Auto Adjust" is displayed. Press the **Enter** key. You will see the following message: "\*ADJUSTING DRIFT\* For 25 Seconds".
14. Make the test measurement.
15. If the reading appears to be drifting, refer to the Drift Adjust discussion in Paragraph 5.9.

# CHAPTER 5

## ADVANCED OPERATION

### 5.0 GENERAL

This chapter provides advance operation instructions for the Lake Shore Model 480 Fluxmeter. Units selection is described in Paragraph 5.1. Coil parameters in Paragraph 5.2. Coil setup in Paragraph 5.3. Making measurements in percent in Paragraph 5.4. Coil calibration in Paragraph 5.5. Coil select and parameter storage in Paragraph 5.6. range selection in Paragraph 5.7. Reading reset in Paragraph 5.8. Drift adjustment in Paragraph 5.9. DC and AC measurement modes in Paragraph 5.10. Peak hold and peak reset in Paragraph 5.11. Filter operation in Paragraph 5.12. Display resolution in Paragraph 5.13. Alarm and relay operation in Paragraph 5.14. Analog outputs in Paragraph 5.15. External reset in Paragraph 5.16. Locking and unlocking the keypad in Paragraph 5.17. And resetting to default values in Paragraph 5.18.

### 5.1 UNITS SELECTION

Units selection is an important step in operating a fluxmeter. Measurement results have a different meaning depending on which units are chosen. Different coil parameters are needed and operating ranges change. There may be only one practical units choice for a given application.

The units available in the Model 480 are summarized in Table 5-1. The table indicates which coil parameters are needed for each unit selection. Unmarked parameters are ignored. Units grouped as integrator, flux or flux density share the same parameter requirements.

The units selected can be used for DC, DC Peak, AC, and AC Peak measurements. Alarm setpoint values can be set in any units. The corrected analog output can be scaled to work with any units. Once units are selected, proceed to the coil setup function to enter the required parameters.

**Table 5-1. Units and Associated Coil Parameters**

Measurement	Units	Coil Resistance (R <sub>coil</sub> )	Turns (N)	Area Turns (A N)*	Potential Constant (P <sub>c</sub> )	Helmholtz Constant (H <sub>c</sub> )	Percent Scale Factor (%C)	System	Equation
Integrator	V•s	■						-	Primary
	WbN	■						-	WbN=V•s
	MxN	■						-	MxN=10 <sup>8</sup> V•s
Flux (φ)	V•sφ	■	●					-	V•sφ=V•s/N
	Wb	■	●					SI	Wb=WbN/N
	Mx	■	●					CGS	Mx=MxN/N
Flux Density (B)	G	■		●				CGS	G=Mx/cm <sup>2</sup>
	T	■		●				SI	T=Wb/m <sup>2</sup>
Potential	A	■			●			SI	-
Moment	Wb•cm	■				●		SI	-
Percent	%	■					●	-	-

\* Will be calculated by the instrument if turns (N) and area (A) are entered first.

■ Required only if a significant percentage of input resistance. Otherwise set to 0 Ω.

● Required coil parameter for the units selected.

### Units Selection (Continued)

To select a unit, press the **Units** key. The following screen appears.

```
Select With ▲▼  
Flux Turns: Us
```

Use the **▲** or **▼** keys to cycle through the different units: **V·s**, **MxN**, **WbN**, **V·sφ**, **Wbφ**, **Mxφ**, **T**, **G**, **%**, **Wb·cm**, or **A**. When the desired unit displays, press the **Enter** key to accept it, or the **Escape** key to exit the screen and revert to the previous unit.

## 5.2 COIL PARAMETERS

Most measurements made with a fluxmeter require some information about the sense coil. The Model 480 offers several ways to obtain and enter the coil parameters. This section briefly outlines the coil related features available in the Model 480.

Lake Shore coils and probes already have necessary coil parameters loaded into them. To use a Lake Shore probe power the instrument off, attach the probe and power it back on. During the power up sequence the instrument will read all loaded coil parameters and coil setup is complete. Most parameters are fixed and can not be changed by the user. The percent constant can be changed and stored in the probe (refer to Paragraph 5.6) to allow percent operation.

Users can purchase the Model FCBL-6 accessory from Lake Shore and program their own coil parameters into the same non-volatile memory used by Lake Shore probes. The user coils act just like factory programmed probes after necessary information is loaded. Coil parameters are entered using the coil setup feature and stored as described in Paragraph 5.3 and 5.6.

For applications that require frequent changing of a few different coils, up to ten sets of coil parameters can be stored in non-volatile memory in the Model 480. After information is stored the coil select function is used to call it up. Coil parameters are entered using the coil setup feature and stored as described in Paragraph 5.6.

For applications where an absolute measurement in magnetic units is not required the Model 480 offers the units of percent. This is intended to be a relative measurement for sorting operations of comparing values. No knowledge of the coil is necessary to measure in percent.

If coil parameters are not known and the user has access to reference magnet or other known field, the Model 480 can be used to calculate the required coil parameter for magnetic measurement units. Refer to the coil calibrate feature (Paragraph 5.5) for details. Once a coil is calibrated the coil setup feature can be used to read the calibrated coil parameter. Calibrated coil parameters can also be stored in instrument memory or a Model FCBL-6 accessory.

## 5.3 COIL SETUP

The coil setup function allows the user to enter coil parameters for their coils. Lake Shore coils and probes do not require this function. Not all the coil parameters that appear sequentially after the **Coil Setup** key is pressed are needed for a coil. Refer to Table 5-1 to determine which parameters are necessary for the measurement units being used. Unknown parameter values should be left at default.

### 5.3.1 Input Resistance

The analog integrator in the Model 480 will not function without an integrating resistance. The integrating resistance is the sum of input resistance and coil resistance. The input resistance parameter tells the Model 480 which input resistance to use inside the instrument. There are three setting values available: 100 k $\Omega$ , 10 k $\Omega$  for normal measurements, and 0  $\Omega$  for special applications.

An input resistance of 100 k $\Omega$  is the default setting and is appropriate for most applications. The Model 480 achieves its best drift performance with this resistance.

An input resistance of 10 k $\Omega$  is used when more sensitivity is required. The full scale for each range setting drops by a factor of ten when input resistance changed from 100 k $\Omega$  to 10 k $\Omega$ . The improved sensitivity may only be useful in the presence of very low drift.

The 0  $\Omega$  input is used rarely when the coil resistance is very high and can act alone as the integrating resistance. In these applications an input resistance inside the instrument would serve only to reduce sensitivity of the measurement. Care must be taken when using the 0  $\Omega$  range. Without a large input resistance the input is more vulnerable to electrostatic discharge (ESD) and other voltage spikes. A non-zero coil resistance **must** be entered for the Model 480 to calculate a display value at all. Because of the potential for problems, the 0  $\Omega$  setting can only be entered with a press and hold operation and if the coil resistance is zero, the display value will blink.

To select an input resistance press the **Coil Setup** key. You will see the following display.

```
Select With ▲▼  
Input R: 100k $\Omega$ 
```

Use the **▲** or **▼** keys to select between 100 k $\Omega$  and 10 k $\Omega$ . Press the **Enter** key to accept the change or the **Escape** key to cancel the entry and return the previous value. The next screen in the coil setup will appear. That parameter can be entered if needed, or press the **Enter** key to continue past it, or press the **Escape** key to return to the normal display.

To select an input resistance of 0  $\Omega$  press and hold the **Coil Setup** key for 5 seconds.

```
Select With ▲▼  
0 $\Omega$  Input: No
```

The 0  $\Omega$  setting screen will appear. Use the **▲** or **▼** keys to select Yes or No. Press the **Enter** key to accept the change or the **Escape** key to cancel the entry and return the previous value. The next screen in the coil setup function will appear. That parameter can be entered if needed, or press the **Enter** key to continue past it, or press the **Escape** key to return to the normal display.

### 5.3.2 Coil Resistance

Coil resistance can often be ignored because it is usually small compared to the input resistance of the Model 480. If the DC resistance of the coil is more than 0.1% of the input resistance it can reduce measurement accuracy and should be entered as a coil parameter. If it is less than that it can be ignored and set to the default value of 0  $\Omega$ . If an input resistance of 0  $\Omega$  is selected, a non-zero coil resistance must be entered for the fluxmeter to make any measurements. If the input and coil resistance are both set to zero the display value will blink.

To enter coil resistance continue from input resistance entry or press the **Coil Setup** key and press the **Enter** key until the **Enter Coil R** screen appears.



```
Enter Coil R
1.00000 _ $\Omega$ 
```

Use the numeric keypad to enter the coil resistance, then press the **Enter** key. The cursor will jump to a space before the  $\Omega$  symbol. Use the  $\blacktriangle$  or  $\blacktriangledown$  keys to select prefix  $\mu$ , m,  $\_$ , k, or M. Press the **Enter** key, then the **Escape** key.

### 5.3.3 Number of Turns (N)

Number of turns in a coil is needed for the Model 480 to make magnetic measurements in flux units. If the number of turns is set to the default of 1 flux measurement values will equal integrator measurement values.

To enter coil number of turns, continue from coil resistance entry or press the **Coil Setup** key and press the **Enter** key until the **Enter Turns** screen appears.

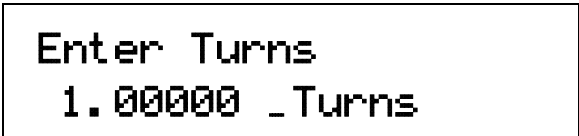

```
Enter Turns
1.00000 _Turns
```

Use the numeric keypad to enter the number of turns (**N**) of the coil, then press the **Enter** key. The cursor will jump to a space before the word "Turns". Use the  $\blacktriangle$  or  $\blacktriangledown$  keys to select prefix  $\mu$ , m,  $\_$ , k, or M. Press the **Enter** key, then the **Escape** key.

### 5.3.4 Area (A)

The Model 480 must have an accurate area turns (AN) value for a coil in order to make flux density measurements. This parameter can be entered in two ways. The user can enter a separate turns value and area value in which case the instrument will calculate and store the area turns product. The user can also enter a value for the area turns parameter directly by pressing the **Enter** key to skip over the area setting screen.

To enter coil area, continue from coil turns entry or press the **Coil Setup** key and press the **Enter** key until the **Enter Area** screen appears.



```
Enter Area
1.00000 _cm2
```

Use the numeric keypad to enter the area (**A**) of the coil in  $\text{cm}^2$ , then press the **Enter** key. The cursor will jump to a space before the " $\text{cm}^2$ ". Use the  $\blacktriangle$  or  $\blacktriangledown$  keys to select prefix  $\mu$ , m,  $\_$ , k, or, M. Press the **Enter** key, then the **Escape** key.

### 5.3.5 Area Turns (AN)

The Model 480 must have an accurate area turns (AN) value for a coil in order to make flux density measurements. The user can also enter a value for the area turns parameter directly from the **Enter Area Turns** screen. If a separate turns value and area value are entered before this screen appears, the calculated area turns product will be stored for this parameter. The new value will not be calculated or displayed until the Coil Setup sequence is complete. If a calculated value is desired continue past the setting screen, if not enter the area turns value. Area turns are entered in  $\text{cm}^2$  units which can be a source of confusion because the area parameter (which is different) uses the same units.

To enter coil area turns, continue from coil area entry or press the **Coil Setup** key and press the **Enter** key until the **Enter Area Turns** screen appears.

```
Enter Area Turns
1.00000 _cm2
```

Use the numeric keypad to enter the product of the area times the number of turns (**A·N**) of the coil in  $\text{cm}^2$ , then press the **Enter** key. The cursor will jump to a space before the " $\text{cm}^2$ ". Use the **▲** or **▼** keys to select prefix  $\mu$ , m, **\_**, k, or, M. Press the **Enter** key, then the **Escape** key. **Remember:** Enter either **A** and **N** or **A·N**; all three need not be entered.

### 5.3.6 Helmholtz Constant

A Helmholtz constant of a Helmholtz coil is required for the Model 480 to make magnetic moment measurements. The only available moment measurement unit is  $\text{Wb}\cdot\text{cm}$  which is a more convenient form of the more traditional  $\text{Wb}\cdot\text{m}$ . The Helmholtz constant must be entered in cm for the display reading to have appropriate resolution. For additional details, refer to Paragraph 2.5.3.

To enter Helmholtz constant, continue from coil area turns entry or press the **Coil Setup** key and press the **Enter** key until the **Helmholtz Constant** screen appears.

```
Helmholtz Constant
0.03530 _cm
```

Use the numeric keypad to enter the Helmholtz constant in cm, then press the **Enter** key. The cursor will jump to a space before the " $\text{cm}$ ". Use the **▲** or **▼** keys to select prefix  $\mu$ , m, **\_**, k, or, M. Press the **Enter** key, then the **Escape** key.

### 5.3.7 Potential Constant

A potential constant of a potential coil is required for the Model 480 to make magnetic potential measurements. The only available potential measurement unit is A. The potential constant must be entered in the empirically derived units of  $\text{A}/\text{Vs}$ .

To enter Potential constant, continue from Helmholtz constant entry or press the **Coil Setup** key and press the **Enter** key until the **Potential Constant** screen appears.

```
Potential Constant
1.00000 _A/Vs
```

Use the numeric keypad to enter the Potential constant in  $\text{A}/\text{Vs}$ , then press the **Enter** key. The cursor will jump to a space before the " $\text{A}/\text{Vs}$ ". Use the **▲** or **▼** keys to select prefix  $\mu$ , m, **\_**, k, or, M. Press the **Enter** key, then the **Escape** key.

## 5.4 MAKING MEASUREMENTS IN PERCENT

For applications where an absolute measurement in magnetic units is not required the Model 480 offers the units of percent. This is intended to be a relative measurement for sorting operations or comparing values. As an example assume a sorting criteria is given as  $\pm 10\%$  deviation from a standard magnet. The standard magnet can be measured with the Model 480. Its measurement scaled to a 100% reading on the display. Magnets measuring between 90% and 110% pass and others fail. The percent scale factor is the coil parameter used to scale a percent measurement. It is the only coil parameter that can be changed on a Lake Shore probe.

### 5.4.1 Before Using Set Percent

The set percent feature can be used to calculate a percent scale factor. The feature can be initiated with the instrument set to any measurement units but if the coil is uncalibrated, it is recommended that the sequence be started with the units set to V·s. Several measurements of the test magnet should be made to assure repeatability. An improper range setting or excess drift can cause difficulty in repeating measurements.

### 5.4.2 Set Percent (%)

Begin the set percent sequence by resetting the reading with the **Reading Reset** key or the peak hold value with the **Peak Reset** key. Make a measurement of the sample magnet or place the coil in a known magnetic environment. Press the **Set Percent** key. The **Enter Percentage** screen will appear on the display.

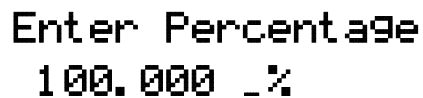

```
Enter Percentage
100.000 _%
```

Use the keypad to enter the percent value that is to be assigned to the measurement (often 100% but it can be different), then press the **Enter** key. The cursor will jump to a space before “%”. Use the **▲** or **▼** keys to select prefix  $\mu$ , m,  $\_$ , k, or, M. Press the **Enter** key to accept the change or the **Escape** key to cancel the entry and return the previous value. The instrument will begin displaying in percent. The sequence is successful if the display reading matches the value entered.

### 5.4.3 Percent Scale Factor

The percent scale factor can be viewed or entered directly. This feature allows the coil to be used again with the same scale factor or transferred from one instrument to another. The scale factor is in the empirical units of  $\%/V\cdot s$ .

To view or change the percent scale factor, press and hold the **Set Percent** key for 5 seconds.



```
Percent Scale Factor
200.000 _%/Vs
```

Use the numeric keypad to enter the Percent Scale Factor in  $\%/V\cdot s$ , then press the **Enter** key. The cursor will jump to a space before the “%”. Use the **▲** or **▼** keys to select prefix  $\mu$ , m,  $\_$ , k, or, M. Press the **Enter** key, then the **Escape** key.

## 5.5 COIL CALIBRATION

If coil parameters are not known and the user has access to reference magnet or other known field, the Model 480 can be used to calculate the required coil parameter for magnetic measurement units. Once a coil is calibrated the coil setup feature can be used to read the calibrated coil parameter. Calibrated coil parameters can also be stored in instrument memory or a Model FCBL-6 accessory.

Coil calibration is disabled for Lake Shore probes because they are calibrated at the factory. Coil calibration is disabled for if the instrument is operating in integrator units because no calibration of the coil is necessary. As described below the feature will only calculate one parameter for each type of magnetic measurement. More than one calibration can be done on the same coil but each calibration is done separately. Coil resistance should be entered before a coil is calibrated if its resistance is meaningful.

Measurement	Units	Parameter
Flux	V·s Wb Mx	Turns (N) Turns (N) Turns (N)
Flux Density	B T	Area Turns (AN) Area Turns (AN)
Moment	Wb·cm	Helmholtz Constant
Potential	A	Potential Constant

### 5.5.1 Before using Coil Calibration

Turn the instrument on and allow it to warm up. Measure the DC coil resistance and enter it with Coil Setup if necessary. Choose the desired measurement units. If the existing value of the coil parameter being calibrated is interfering with the measurement resolution set it to 1 using Coil Setup. Make several measurements of the test magnet to assure repeatability. An improper range setting or excess drift can cause difficulty in repeating measurements.

### 5.5.2 Calibrating a Coil

Begin the coil calibration sequence by resetting the reading with the **Reading Reset** key or the peak hold value with the **Peak Reset** key. Make a measurement of the sample magnet or place the coil in a known magnetic environment. Press the **Coil Cal** key. The **COIL CAL** screen will appear on the display. Enter the actual value of the field in the chosen units. Press the **Enter** key to accept the change or the **Escape** key to cancel the entry and return the previous value. The instrument will begin reading with the new coil parameter. The sequence is successful if the display reading matches the value entered.

## 5.6 COIL SELECT AND PARAMETER STORAGE

The Model 480 has non-volatile internal memory available to store up to ten sets of coil parameters for user coils. All coil parameters (including input resistance and percent scale factor) can be stored in each of the ten memory locations. Unused parameters can be left at their default value. Once the parameters are stored they can be called up quickly whenever coils are changed.

This feature can be used to store parameter values in a Model FCBL-6 accessory and percent scale factor into Lake Shore probes. Parameters stored in probe memory are called up when the instrument is turned on.

### 5.6.1 Storing New Coil Parameters into Instrument Memory

Turn the instrument Off (O) and attach the new coil to the rear of the instrument. Turn power On (I). Push the **Coil Setup** key and enter all relevant coil parameters as detailed in Paragraph 5.3. This accomplished, press and hold the **Coil Select** key until you see the following display.

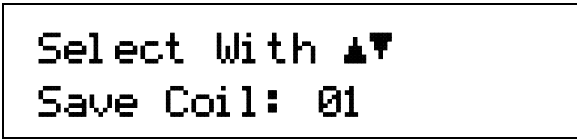

```
Select With ▲▼  
Save Coil: 01
```

Use the ▲ or ▼ keys to cycle through the storage locations (1-10). When you reach the desired coil location, press the **Enter** key, or press the **Escape** key to cancel and return to the normal display.

### 5.6.2 Storing New Coil Parameters into Probe Memory

The Lake Shore Model FCBL-6 User Programmable Coil Interconnect Cable is designed to allow a customer to mate an in-house designed coil to the Model 480 Fluxmeter, taking full advantage of the internal PROM programming capability. Connect the FCBL-6 to the user coil per instruction in Paragraph 3.5.1.

Turn the instrument Off (O) and connect the FCBL-6 to the PROBE INPUT connector at the rear of the instrument. Turn power On (I). Push the **Coil Setup** key and enter all relevant coil parameters as detailed in Paragraph 5.3. This accomplished, press and hold the **Coil Select** key. You will see the following display.

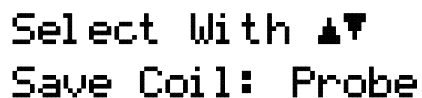

```
Select With ▲▼  
Save Coil: Probe
```

Use the ▲ or ▼ keys to select "PROBE." Press the **ENTER** key, or press the **Escape** key to cancel and return to the normal display.

After the PROM is loaded with the necessary coil parameters, nothing more is required for future use of that coil, except to turn off the Model 480, attach the cable, and turn power back on.

### 5.6.3 Selecting Saved Coil Parameters

To select the parameters of a coil that were previously saved in instrument memory, press the **Coil Select** key. You will see the following display.



```
Select With ▲▼  
Select Coil: 01
```

The numbers 01 thru 10 correspond to instrument memory locations for coil parameters. "User" indicates that parameters have been changed since the last time the coil was selected from memory. Use the ▲ or ▼ keys to cycle thru the available selections. Press the **Enter** key to make a selection, or press the **Escape** key to cancel and return to the normal display.

**NOTE:** "Probe" will be seen when the Model 480 detects a probe attached to the instrument. When a probe is attached, instrument memory locations cannot be selected.

## 5.7 RANGE SELECTION

Range selection is difficult to define for the Model 480 because of its different measurement units but the operation is simple. The input range can be increased to measure large signals or decreased to measure smaller signals with better resolution. All available ranges are accessible during range selection. At that time the full scale range and reading resolution will be shown. Full-scale range and resolution are listed for V-s units in the Specifications detailed on Page 1-2.

There are two decade range selections available for DC and DC peak measurements. Input resistance (Paragraph 5.3.1) can be changed to allow a third decade of measurement range. Coil construction can also be changed to alter the range boundaries in magnetic units. The DC range setting is stored separately from the AC range setting.

There are four decade range selections available for AC measurements and three for AC Peak measurements. More ranges are allowed for AC because they do not suffer from the drift associated with DC measurements. Drift on the high gain ranges make them unusable for DC measurement. A smaller integrating capacitor is used for AC measurements allowing even more gain. The difference in capacitance is why the largest full scale AC range is smaller than the largest full scale DC range. AC ranges are specified with 100 k $\Omega$  input resistance. Coil construction can be changed to alter the range boundaries in magnetic units.

As an example of coil parameters altering range boundaries consider using the highest DC range of 300 mV-s. If a coil with an area turns of 100 cm<sup>2</sup> is used on the highest DC range for flux density measurements the resulting range boundary in gauss would be 300 kG. If a coil with an area turns of 1000 cm<sup>2</sup> is used on the same range the resulting range boundary would be 30 kG.

If coil parameters are entered and units are selected before range is chosen the Model 480 will calculate and display the appropriate full scale range and resolution in the selected units. Because of the construction of the Model 480 some over range should be expected. Over range is typically 10% of the full scale shown but it is not guaranteed.

To changing the range, press the **Range** key. The following is a typical display.

```
Select With ▲▼
+/- 30.0000 mVs
```

Use the ▲ or ▼ keys to cycle thru the available ranges. Press the **Enter** key to accept or press the **Escape** key to cancel and return to the normal display.

## 5.8 READING RESET

The analog integrator in the Model 480 must be reset to zero at the beginning of a DC measurement sequence. Resetting the integrator removes any flux change or integrator drift that has accumulated since the last reset. The DriftTrak™ algorithm (Paragraph 5.9.3) can greatly reduce the number of resets needed for DC measurements. AC and AC Peak measurements do not require reading reset because modifications to the integrator bring the reading to zero when no signal is present. DC Peak measurements require peak reset (Paragraph 5.11.4) instead of reading reset.

The integrator in the Model 480 is designed to recover quickly from a reading reset. A new reading is available 200 ms after the **Reading Reset** key is released. Reading reset can also be achieved through computer interface or using the external reset feature (Paragraph 5.16).

If the Model 480 appears to have more drift just after a reset than it does 10 to 30 seconds later it could be a result of dielectric absorption (Paragraph 2.1.5). If the resulting error in reading is too large for the measurement application the error can be reduced by resetting a second time a few seconds after the first reset.

To reset the reading press the **Reading Reset** key and release.

## 5.9 DRIFT ADJUSTMENT

Drift Adjustment is a fact of life when making DC and DC Peak measurements with an analog integrator like the one in the Model 480. Drift is caused by offsets present in the integrator components and coil connections. AC and AC Peak measurements do not require drift adjustment because modifications to the integrator bring the reading to zero when no signal is present.

Drift is related to instrument hardware and often temperature change. The Model 480 has been designed to minimize drift but there are some important things to do during setup when low drift is important.

1. Let the instrument warm up before attempting to adjust drift. Allow 30 minutes for normal use and longer if the instrument is stored in an unheated area.
2. Attach the coil that will be used with the fluxmeter before drift is adjusted.
3. Make sure coil connections are tight.
4. Keep coil leads as short as possible and have as few connections as possible.
5. Shield coil contacts from fast temperature changes.

The Model 480 has replaced the drift adjustment trim-potentiometer present on older fluxmeters with two internal digital-to-analog converters (DACs) for drift compensation. These converters can be set from the keypad for very precise manual drift adjustment or controlled by the instrument for hands off drift adjustment. The paragraphs below describe three ways to adjust drift with the Model 480. All drift adjustments must be made with no changing field present at the coil.

### 5.9.1 Automatic Drift Adjustment

The Model 480 can adjust drift by measuring the change in reading over a fixed time interval and calculating the appropriate coarse drift compensation DAC value. The sequence takes approximately 25 seconds. A well calculated coarse DAC value will give acceptable drift performance for most applications. The fine drift compensation DAC is set to 0 during the operation. The fine DAC can be set manually or by the DriftTrak algorithm for improved drift performance. An error message will appear on the instrument display if automatic drift adjustment failed. If the message appears, check all coil connections, allow the instrument more time to warm up, and try again.

After the coil is connected and the instrument has warmed up, initiate automatic drift adjustment by pressing the **Drift Adjust** key. The message `Begin Auto Adjust` will appear. Press the **Enter** key to start or the **Escape** key to return to the main display. If you pressed the Enter key, you will see the following display.

**\*ADJUSTING DRIFT\***  
**For 25 Seconds**

The message will remain visible for 25 seconds, then return to the normal display. Pressing the **Escape** key during this time will cancel the sequence and return to normal operation.

### 5.9.2 Manual Drift Adjustment

For manual drift adjustment the two drift compensation DACs in the Model 480 can be thought of as precise trim potentiometer adjustments. Each has a range of 0 to 100% and an effective resolution of 0.025%. The coarse DAC should be set before the fine DAC if the coil has been changed or the instrument has been turned off. During normal operation only fine DAC adjustments should be required.

After the coil is connected and the instrument has warmed up, initiate manual drift adjustment by pressing the **Drift Adjust** key. Use the **▲** or **▼** keys until the **Begin Manual Adjust** message appears. Press the **Enter** key and the course DAC setting screen will appear.

```
+ 0.0010 _G   DC
- 3.51% Coarse
```

Use the **▲** or **▼** keys until the display reading stops changing in one direction. Press the **Enter** key again and the fine DAC setting screen will appear.

```
+ 0.0010 _G   DC
+ 0.04% Fine
```

Use the **▲** or **▼** keys until the drift in the display reading is acceptable. Press the **Enter** key to complete the operation. Press the **Escape** key during either adjustment to cancel the adjustment and return to normal operation.

### 5.9.3 DriftTrak

DriftTrak is a proprietary drift control algorithm exclusive to Lake Shore Fluxmeters. It is different than automatic and manual drift adjustment because it operates continuously keeping drift low over time. DriftTrak works best after automatic drift adjustment has reduced drift to a low starting point. The algorithm works only in DC mode. For DC Peak operation the instrument should be allowed to idle in DC mode when not in use and switched to DC Peak before being used.

The DriftTrak algorithm continuously monitors changes in the fluxmeter reading. If the changes are large the algorithm assumes an actual change in measured field and shuts itself off for a short time. When shut off, DriftTrak will not affect active measurements. If changes are small the algorithm assumes the fluxmeter is idle and any changes in reading are caused by drift. During this time new values for the drift compensation DACs are calculated and stored. The limit separating large and small changes is called a threshold and can be changed by the user for different applications and system noise levels.

It is important to understand that idle time is necessary for DriftTrak operation. The algorithm becomes active if the change threshold is not exceeded for only a few seconds but it can take a minute or more for the calculated DAC setting to have an impact on drift performance. Best performance will be achieved if the algorithm has 10 to 20 minutes to operate on an idle instrument.

The default settings for the instrument are DriftTrak on and a change threshold of 200  $\mu\text{V}\cdot\text{s}/\text{min}$ . The recommended operating range for the threshold is 100 to 1000  $\mu\text{V}\cdot\text{s}/\text{min}$  and it can only be set in  $\mu\text{V}\cdot\text{s}/\text{min}$ . Lower settings are for quiet systems measuring slow changes in field. Higher settings are for noisy systems measuring fast changes in field.

**DriftTrak (Continued)**

To turn the DriftTrak algorithm on or off press the **Drift Adjust** key. The message **Begin Auto Adjust** will appear. Use the ▲ or ▼ keys until the **Set DriftTrak** message appears.

```
Select With ▲▼  
Set DriftTrak
```

Press the **Enter** key. You now see the DriftTrak On/Off display.

```
Select With ▲▼  
DriftTrak: On
```

Use the ▲ or ▼ keys to toggle between DriftTrak On or Off. Press the **Enter** key. The instrument will return to the normal display.

To set the DriftTrak threshold, press and hold the **Drift Adjust** key until you see the following display.

```
Enter Threshold  
200  $\mu$ Vs/min
```

Use the numeric keypad to enter the DriftTrak threshold in  $\mu$ V-s/minute, then press the **Enter** key. The instrument will return to the normal display.

**5.10 DC AND AC MEASUREMENT MODES**

The Model 480 can be used to measure non-repetitive field changes in DC mode or repetitive field changes in AC mode. These measurements are different and many sections in this chapter differentiate between DC and AC operation.

**5.10.1 DC Measurement Mode**

DC measurement are the most common type of magnetic measurement associated with fluxmeters. Permanent magnet testing and sorting are often done in DC mode. Magnet characterization in an electromagnet system requires good DC performance. The peak hold should be used with DC mode for pass through magnet testing or any other application where field changes are only present for a short time.

Drift is the dominant error seen in DC mode often limiting range and repeatability. Drift compensation and integrator resets are always necessary when making DC measurements. For best performance leave DriftTrak on whenever possible.

To select DC mode press the **AC/DC** key. DC operation is indicated by the letters **DC** on the normal display to the right of the units indicator.

### 5.10.2 AC Measurement Mode

AC mode is a natural extension of the measurement capabilities of an integrating DC fluxmeter. With the selection of only a few different parts the Model 480 is made ready to measure periodic AC fields. These fields may be present as stray field around transformers or leakage from switching power supplies. AC mode measures in RMS and only the AC part of the field change is represented in the reading value; the steady state DC field is ignored. Peak hold can be used with AC mode to measure the peak value of periodic fields or to capture fast transients as described in Paragraph 5.11.

AC measurements do not require drift compensation or integrator reset because modifications to the integrator bring the reading to zero when no signal is present. Frequency response and noise dominate the error present in AC mode. The Model 480 has a predictable frequency response which is illustrated in Figure 5-1. Sense coils also have a frequency response which can limit accuracy. AC measurements can be susceptible to noise because most fields are small and require a low measurement range. It may be necessary to shield environmental noise during low field AC measurements.

The RMS converter in the Model 480 requires a significant signal amplitude for proper operation. AC measurements are specified with a minimum reading for each range because of the RMS converter. If the input amplitude is below the specified minimum the AC annunciator will blink on the instrument display. The minimum reading is different for AC peak operation because the RMS converter is bypassed.

To select AC mode press the **AC/DC** key. AC operation is indicated by the letters **AC** on the normal display to the right of the units indicator.

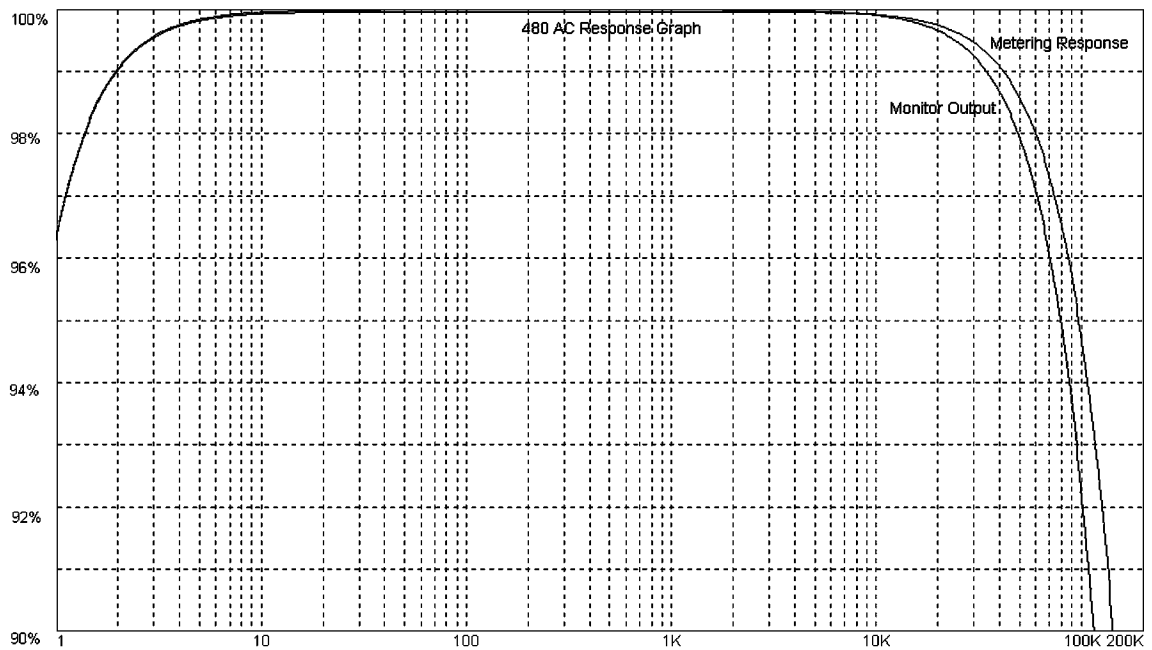

Figure 5-1. Model 480 AC Frequency Response

P-480-5-1.bmp

## 5.11 PEAK HOLD AND PEAK RESET

The Model 480 has high speed peak hold hardware that can be used to capture positive and negative peak values. Software stores the measured peaks to prevent any sag in the hold circuits from changing the display value. Peak hold operation can be used during DC or AC operation.

### 5.11.1 Peak Hold in DC Mode

The peak hold feature has very little effect on DC mode operation. The peak hold circuit captures and holds the highest and lowest value present in the DC signal path since the last peak reset. The circuit is many times faster than the instrument update rate and can capture and hold signals that cannot otherwise be seen on the display. The peak hold circuit was designed to keep up with the fastest magnetizing pulses.

Drift is as much a problem in DC Peak mode as DC mode. Drift compensation and integrator resets are necessary when making DC Peak measurements. DriftTrak does not attempt to correct drift during DC Peak operation.

### 5.11.2 Peak Hold in AC Mode

During AC mode operation the peak hold feature bypasses the RMS converter. The peak amplitude of a periodic wave form is believed to be more useful than the maximum RMS value. The highest and lowest "peak" AC values (not RMS values) present in the AC signal path are captured and held. This distinction can cause some confusion. For a sinusoidal wave form the peak value is approximately 1.4 times higher than the RMS. For non-sinusoidal wave forms the difference can be much larger.

AC Peak mode uses the same fast peak hold circuit as DC Peak mode enabling operation over a wide frequency range for periodic signals. No drift compensation is required for AC Peak operation. Non-periodic field changes can also be captured using AC Peak mode. There are several possible applications, including magnetizers, for a drift free integrator with several gain ranges and a high speed peak hold.

### 5.11.3 Activating Peak Mode

To turn peak mode On or Off, press the **Peak Hold** key. The screens below illustrate positive peak, negative peak, and both peaks.

```
^+2.9758 kG DC
```

```
√-1.8736 kG DC
```

```
^+2.9758 kG DC  
√-1.8736 kG
```

**NOTE:** The up caret (^) or down caret (√) next to the peak reading indicates positive or negative peak operation, respectively.

#### 5.11.4 Peak Reset

In DC Peak mode the integrator, peak hold hardware and peak hold software must all be reset before another reading can be made. The peak reset function does all three from the front panel using the **Peak Reset** key, over computer interface or with external reset. The **Reset Reading** key still functions to reset the integrator only but its use is not recommended.

In AC Peak mode the peak hold hardware and peak hold software are reset using the **Peak Reset** key. The integrator does not require reset.

The instrument is available for new readings 200 ms after the **Peak Reset** key is released if one peak value is being measured and 400 ms if both are being measured.

To reset peak press the **Peak Reset** key and release.

#### 5.11.5 Choosing Positive, Negative or Both Peaks

Peak hold hardware in the Model 480 is capable of capturing both positive and negative peaks at the same time. Either one or both of the values can be displayed. The instrument defaults to displaying of both peaks. If both peaks are displayed the instrument update rate and peak reset time are slowed. The instrument can read both peak values in about one fourth the normal update rate. Peak reset time is doubled.

To select positive or negative peak, press and hold the **Peak Hold** key for 5 seconds. The following screen is displayed.

```
Select With ▲▼  
Peak Mode: Both
```

Use the ▲ or ▼ keys to select Positive, Negative, or Both peaks. When the cursor indicates the desired peak, press the **Enter** key to accept it, or the **Escape** key to exit the screen and revert to the previous peak.

#### 5.12 FILTER

The display filter function quiets the display making it more readable when the probe is exposed to a noisy field. Take care when using the filter on changing fields; it may slow instrument response. Users may configure the filter function to view desired field changes and block noise. The filter is not used in Peak Hold.

To turn on the display filter, press the **Filter** key to display the following screen.

```
Select With ▲▼  
Filter On →Off
```

Press the **Filter** key or the ▲ or ▼ keys to toggle between On and Off. Press the **Enter** key to accept the new setting or the **Escape** key to retain the old setting and return to the normal display.

**Filter (Continued)**

When the Filter is turned on, two additional displays appear. The first is Filter Points. The Filter Points display sets the number of points to use in the filter algorithm.

```
Select With ▲▼  
Filter Points 08
```

Use the ▲ or ▼ keys to increment or decrement the Filter Points number from 2 to 64 points (8 is the default). The unit takes one point each update cycle, so filter settling time depends on update speed and number of points. Press the **Enter** key to accept the new setting or the **Escape** key to retain the old setting and return to the normal display.

The Model 480 uses an exponential algorithm to smooth response. The settling time to full display resolution is about the same as the number of filter points in seconds. For example, a setting of 10 filter points settles in about 10 seconds.

The second display is Filter Window. The Filter Window display sets a limit for restarting the filter.

```
Select With ▲▼  
Filter Window 10%
```

Press the **Filter** key or the ▲ or ▼ keys to increment or decrement the Filter Window percentage from 1% to 10% (1% is the default). Press the **Enter** key to accept the new setting or the **Escape** key to retain the old setting and return to the normal display.

If a single field reading differs from the filter value by more than the limit specified, the instrument assumes an intentional change and restarts the filter at the new reading value. This allows faster instrument response to changing fields than if the filter functioned continually.

**5.13 DISPLAY RESOLUTION**

The DC Mode display resolution, or number of digits shown on the display, can be changed between  $5\frac{3}{4}$  and  $4\frac{3}{4}$  digits. The parameter does not change DC Peak, AC, or AC Peak resolution. To change the display resolution, press and hold the **Filter** key for 5 seconds. The following screen is displayed.

```
Select With ▲▼  
DC Res: 5 3/4 Digits
```

Use the ▲ or ▼ keys to select  $5\frac{3}{4}$  or  $4\frac{3}{4}$  digits. Press the **Enter** key to accept it, or the **Escape** key to retain the old setting and return to the normal display.

**5.14 ALARM AND RELAY OPERATION**

The alarm feature on the Model 480 has enough flexibility to support several Pass/Fail configurations in addition to simple fault detection. A display annunciator and audible beeper signal an active alarm at the instrument. Alarm states can be assigned to up to three relays for external monitoring or automated control. If both peak readings are displayed the alarms follow the positive peak.

### 5.14.1 Alarm Setup

There are four parameters associated with alarm setup. The high and low setpoints are the alarm boundaries. In general if the measurement value crosses a boundary an alarm state will change. The setpoints are entered in the units selected for the display. They are entered as magnitude only and are active for both positive and negative measurement values as shown in Figure 5-2. The alarms are non-latching so the alarm state will change as soon as the alarm condition is removed.

To set alarm setpoints, press the **Alarm Setup** key. The first screen is as follows.

```
Enter High Alarm
 2.50000 kG
```

Use the numeric keypad to enter the high alarm setpoint (magnitude only). The cursor will jump to a space before the unit, in this case "G". Use the ▲ or ▼ keys to select prefix  $\mu$ , m,  $\_$ , k, or, M. Press the **Enter** key. The "Enter Low Alarm" screen then appears.

```
Enter Low Alarm
 1.50000 kG
```

Use the numeric keypad to enter the low alarm setpoint (magnitude only). The cursor will jump to a space before the unit, in this case "G". Use the ▲ or ▼ keys to select prefix  $\mu$ , m,  $\_$ , k, or, M. Press the **Enter** key.

The alarm mode can be set to inside or outside. Outside is the more common alarm operating mode where a low alarm state is active when the measured value is below the low setpoint and a high alarm is active when the measured value is above the high setpoint. When sorting permanent magnets in outside mode an active alarm indicates a failed part. Inside mode reverses the operation of the audible alarm and annunciator. An alarm is active when the measured value is between the alarm setpoints. When sorting permanent magnets in inside mode an active alarm indicates a good part.

After the "Enter Low Alarm" display, the next display is the "Alarm In/Out" screen.

```
Select With ▲▼
Alarm In →Out
```

Use the ▲ or ▼ keys to cycle between triggering the inside (In) or outside (Out) the high and low setpoints. Once selected, press the **Enter** key.

After the "Alarm In/Out" display, the next display is the "Audible On/Off" screen.

```
Select With ▲▼
Audible On →Off
```

Use the ▲ or ▼ keys to cycle between turning the audible alarm On or Off. Once selected, press the **Enter** key, then press the **Escape** key.

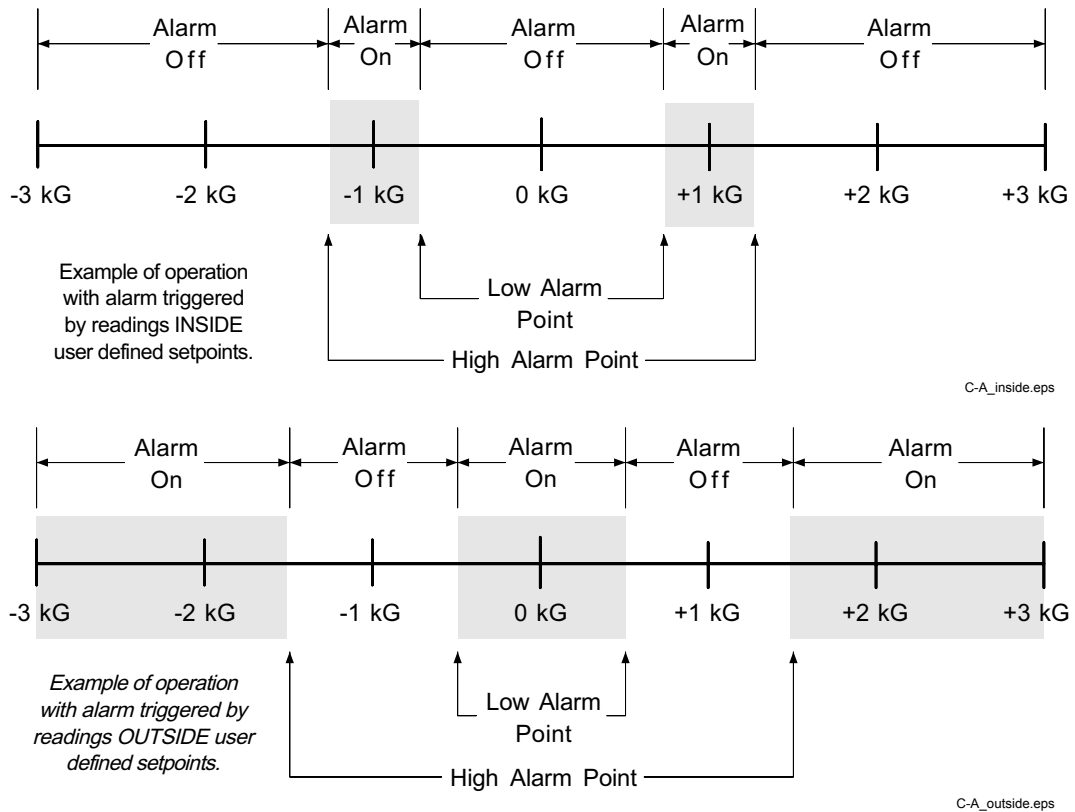

**Figure 5-2. Examples of Alarm Activation Inside and Outside High and Low Setpoints**

**5.14.2 Relay Setup**

There are three relays on the Model 480. Each relay can be set to one of three modes, Automatic, On or Off. In automatic mode the relays follow the alarm status. The high relay is activated when the measured value exceeds the high setpoint, the low alarm relay is activated when the measured value is below the low setpoint and the middle relay is active when the measured value is between the setpoints. Relay operation ignores the Inside/Outside parameter. Relay terminals are located in the detachable terminal block on the rear panel of the instrument.

With On or Off modes the relays can be controlled manually for testing hardware or to control external devices unrelated to alarm function.

To set relay status, press the **Alarm Setup** key. You will see the “**Enter High Alarm**” display. Press the **Enter** key until you see the “**High Relay:**” display.

```

Select With ▲▼
High Relay:   Off
    
```

Use the ▲ or ▼ keys to cycle between On, Off, and Auto. Once selected, press the **Enter** key. You will see the next display. “**on**” indicates an active relay state, while “**off**” indicates a normal relay state.

```

Select With ▲▼
Middle Relay: Off
    
```

**Relay Setup (Continued)**

Use the ▲ or ▼ keys to cycle between On, Off, and Auto. Once selected, press the **Enter** key. You will see the next display.

```
Select With ▲▼
Low Relay:      Off
```

Use the ▲ or ▼ keys to cycle between On, Off, and Auto. Once selected, press the **Enter** key. The screen will return to the normal display.

**5.14.3 Turning Alarm On and Off**

Once the alarm feature is setup it can be activated conveniently with a single key. Press the **Alarm On/Off** key to turn the alarm feature on or off. The music note (♯) annunciator appears on the display when the feature is on. The annunciator blinks and the audible alarm sounds when an alarm is active. All alarm functions are non-latching and do not require a reset.

**5.15 ANALOG OUT OPERATION**

The Model 480 has two analog voltage outputs, **Corrected** and **Monitor**. The two outputs are quite different and not always suitable for the same applications.

**5.15.1 Corrected Analog Output**

The Model 480 digitally generates the corrected analog output voltage with a DAC. This output is not real time. It is updated 30 times a second during normal operation. In dual-peak (both) mode, the Corrected Analog Output alternates between the positive and negative peak values 7 times a second. For a steady-state output, either the positive or negative peak mode must be selected. Instrument and coil calibrations can be taken into account making the corrected output more accurate than the monitor output. The corrected output voltage is scaled to the DC reading value in DC mode, the peak value in DC Peak or AC Peak modes and the RMS value in AC mode.

The corrected output is a variable DC voltage source that can vary from +10 V to -10 V. Voltage is generated by a 16-bit DAC with a resolution of 0.3 mV or 0.003% of 10 V. The output is short protected but should never be used to drive a resistance of less than 1 kΩ for specified accuracy. Analog output terminals are in the detachable terminal block on the rear of the instrument.

The corrected output has three modes of operation, default, user and manual. When the output is being setup the mode must be selected first. Only parameters related to the selected mode will be shown on setting screens.

To set the corrected analog output mode, press the **Analog Out** key to display the following screen.

```
Select With ▲▼
Analog Mode:  Default
```

Use the ▲ or ▼ keys to cycle through the mode selections described below. When the cursor indicates the desired mode, press the **Enter** key to accept it, or the **Escape** key to exit the screen and revert to the previous mode.

### Corrected Analog Output (Continued)

**Default:** In default mode the corrected analog output mimics the monitor output. The output is scaled to V·s units no matter what units are selected for the display. Full scale for the selected range is scaled to 3 V so for example on the 300 mV·s range a +300 mV·s reading would give a +3 V output and a -300 mV·s reading would give a -3 V output. The scale is changed automatically when range is changed.

**User:** In user mode the user selects a value that corresponds to the maximum voltage output (+10 V) and a value that corresponds to the minimum voltage output (-10 V). In this mode the user can scale the analog output to improve resolution over an area of interest. Maximum and minimum values are entered in the units selected for the display. The instrument scales output voltage between the two values.

When “**Analog Mode: User**” is selected, you will see the “**Enter Max Output**” screen.

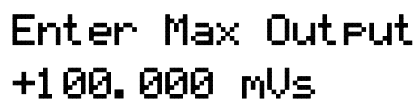

```
Enter Max Output
+100.000 mVs
```

Use the numeric keypad to enter a high reading value that results in +10 V output, then press the **Enter** key. The cursor will jump to a space before the units. Use the ▲ or ▼ keys to select prefix  $\mu$ , m,  $\_$ , k, or, M. Press the **Enter** key. The “**Enter Min Output**” screen then appears.

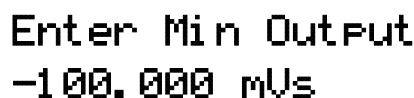

```
Enter Min Output
-100.000 mVs
```

Use the numeric keypad to enter a low reading value that results in -10 V output, then press the **Enter** key. The cursor will jump to a space before the units. Use the ▲ or ▼ keys to select prefix  $\mu$ , m,  $\_$ , k, or, M. Press the **Enter** key.

**Manual:** In manual mode the corrected output voltage can be set directly by the user. The output is set in percent of full scale where +100% corresponds to +10 V and -100% corresponds to -10 V. The setting resolution on the display is 0.001% but the actual resolution of the DAC is only 0.003%.

When “**Analog Mode: Manual**” is selected, you will see the “**Enter AOut Voltage**” screen.

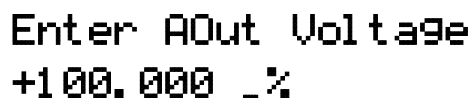

```
Enter AOut Voltage
+100.000 _%
```

Use the numeric keypad to enter the percent of full scale that results in  $\pm 10$  V output, then press the **Enter** key. The cursor will jump to a space before the “%”. Use the ▲ or ▼ keys to select the “ $\_$ ” prefix. Press the **Enter** key.

#### 5.15.2 Monitor Analog Output

The monitor is a real time analog voltage proportional to the integrator output. The wave shape exactly duplicates that of the integrator output. The scale of the monitor output is  $\pm 3$  V for the full scale volt-seconds of the range selected. The monitor output remains scaled to V·s even when other units are displayed. The monitor output is not as accurate as the corrected output because instrument and coil calibrations are digitally processed and do not act on the monitor voltage. There is no user control of the monitor output. The output is short protected but should never be used to drive a resistance of less than 1 k $\Omega$  for specified accuracy. Analog output terminals are in the detachable terminal block on the rear of the instrument.

## 5.16 EXTERNAL RESET

The Model 480 terminal block has connections for external reset. With this feature, a foot pedal or Programmable Logic Controller (PLC) can be used to start a new measurement cycle. The External Reset is TTL compatible and a logic low will activate a reset. The signal is internally pulled up to allow operation with a simple switch closure between Pins 12 and 13.

The external reset acts like a reading reset in DC mode and a peak reset in DC Peak and AC Peak mode. Short the reset line or take it to logic low for at least 1 ms and then open it. Reset completes 200 ms after the reset line is shorted, or 400 ms for Dual Peak.

## 5.17 OPTIONAL INPUT

The Model 480 terminal block has a connection for an optional logic input. It is commonly used to monitor status of a thermostat or proximity switch. The Model 480 monitors the logic level of this input which can then be read over computer interface. The input is TTL compatible. A logic low will produce a 0 interface response and a logic high will produce a 1 interface response. The signal is internally pulled up to allow operation with a simple switch closure between Pins 14 and 13.

The OPTIN? query can be used with IEEE-488 or RS-232C Computer Interface to verify the status of the input. Allow 100 ms for an input status change to appear in the interface response.

## 5.18 LOCKING AND UNLOCKING THE KEYPAD

The Model 480 front panel keypad can be locked to prevent unauthorized changes to settings. To lock the keypad, press and hold the **Enter** key until the following screen is displayed.



Enter Code To  
Lock Keypad

Enter the 3-digit lock code (default: 123). Upon entry of the third digit, the display reverts to the normal display and the keypad locks. After locking, any attempt to change settings displays the \*Locked\* message shown as follows.



\*Locked\*

To unlock the keypad, press and hold the **Enter** key until the following screen is displayed.



Enter Code To  
Unlock Keypad

Enter the lock code again. Upon entry of the third digit, the display reverts to the normal display and the keypad unlocks.

The lock code can be changed using either the IEEE-488 or RS-232C Computer Interface. If the instrument is reset (Paragraph 5.19), the lock code reverts to 123. The instrument cannot reset with the keypad locked.

### 5.19 RESETTING TO DEFAULT VALUES

To reset all instrument parameters to default values, press and hold the **Escape** key for 10 seconds. Table 5-2 lists default values for each parameter. Parameters stored in probes are not reset.

When you press and hold the **Escape** key for 10 seconds, you see the following screen.

```
Code date: 02/26/99
Default Values: No
```

Use the ▲ or ▼ keys to select Yes or No. “Yes” means you wish to reset the instrument to the default settings detailed in Table 5-2. “No” means you do not wish to reset the instrument. When the display indicates the desired selection, press the **Enter** key to accept it, or the **Escape** key to exit the screen and revert to the previous mode.

If you select the **Enter** key, you see the following screen.

```
Code date: 02/26/99
Clear Coils: No
```

Use the ▲ or ▼ keys to select Yes or No. “Yes” means you wish to delete the User-stored coil parameters. “No” means you do not wish to delete the coil parameters. When the display indicates the desired selection, press the **Enter** key to accept it, or the **Escape** key to exit the screen and revert to the previous mode.

**Table 5-2. Default Values**

<u>Command</u>	<u>Function</u>	<u>Interface</u>	<u>Display</u>
<b>Common Commands</b>			
*ESE	Std. Event Status Enable Report.....	000.....	Disabled
*SRE	Service Request Enable Register Report.....	000.....	Disabled
<b>Interface Commands</b>			
ADDR	Set IEEE-488 Address.....	12.....	12
BAUD	Set Serial Interface Baud Rate.....	2.....	9600 Baud
END	Set End Or Identify (EOI).....	0.....	EOI Enabled
MODE	Set Local/Remote Mode.....	0.....	Local Mode
TERM	Set Terminating Character Type.....	0.....	<CR><LF>
<b>Device Specific Commands</b>			
ACDC	Set AC/DC Field Reading Mode.....	0.....	DC
ALARM	Set Alarm Function.....	0.....	Off
ALMB	Set Audible Alarm Function.....	0.....	Off
ALMH	Set Alarm High Point.....	+0.00000.....	+0.00000
ALMIO	Set Alarm Trigger In/Out Mode.....	0.....	Outside
ALML	Set Alarm Low Point.....	+0.00000.....	+0.00000
ANOCN	Set Analog Out Control.....	+0.00000.....	+0.00000%
ANOH	Set Analog Out High Point.....	+0.00000.....	+0.00000
ANOL	Set Analog Out Low Point.....	+0.00000.....	+0.00000
ANOM	Set Analog Out Mode.....	0.....	Default
BRIGT	Set Display Brightness.....	2.....	75%
CODE	Set Keyboard Lock Code.....	123.....	123
COILA	Set Coil Area.....	+1.00000.....	+1.00000 cm <sup>2</sup>
COILAN	Set Coil Area-Turns.....	+1.00000.....	+1.00000 cm <sup>2</sup> N
COILIN	Set Coil Input Terminal.....	2.....	100 kΩ
COILKH	Set Coil Helmholtz Constant.....	+1.00000.....	+1.00000 cm
COILKP	Set Coil Potential Constant.....	+1.00000.....	+1.00000 A
COILN	Set Coil Number of Turns.....	+1.00000.....	+1.00000
COILNUM	Set Coil Number.....	1.....	1
COILR	Set Coil Resistance.....	+0.00000.....	+0.00000 Ω
FILT	Set Display Filter Function.....	0.....	Off
FNUM	Set Filter Points.....	8.....	8
FWIN	Set Filter Window.....	1.....	1%
LOCK	Set Keyboard Lock Mode.....	0.....	Off
PCTMUL	Set Percent Multiplier Constant.....	+1.00000.....	+1.00000
PEAK	Set Peak Hold Function.....	0.....	Off
PEAKM	Set Peak Capture Mode.....	2.....	Dual Peak
RELAYH	Set High Relay Mode.....	0.....	Manual Off
RELAYL	Set Low Relay Mode.....	0.....	Manual Off
RELAYM	Set Middle Relay Mode.....	0.....	Manual Off
RNGAC	Set AC Range.....	0.....	30 mV·s
RNGDC	Set DC Range.....	0.....	300 mV·s
UNITS	Set Display Units.....	1.....	V·s

This Page Intentionally Left Blank

# CHAPTER 6

## COMPUTER INTERFACE OPERATION

### 6.0 GENERAL

This chapter provides operational instructions for the computer interface for the Lake Shore Model 480 Fluxmeter. Either of the two computer interfaces provided with the Model 480 permit remote operation. The first is the IEEE-488 Interface described in Paragraph 6.1. The second is the Serial Interface described in Paragraph 6.2. The two interfaces share a common set of commands detailed in Paragraph 6.3. Use only one of the interfaces at a time.

### 6.1 IEEE-488 INTERFACE

The IEEE-488 Interface is an instrumentation bus with hardware and programming standards that simplify instrument interfacing. The Model 480 IEEE-488 Interface complies with the IEEE-488.2-1987 standard and incorporates its functional, electrical, and mechanical specifications unless otherwise specified in this manual.

All instruments on the interface bus perform one or more of the interface functions of TALKER, LISTENER, or BUS CONTROLLER. A TALKER transmits data onto the bus to other devices. A LISTENER receives data from other devices through the bus. The BUS CONTROLLER designates to the devices on the bus which function to perform. The Model 480 performs the functions of TALKER and LISTENER but cannot be a BUS CONTROLLER. The BUS CONTROLLER is the digital computer which tells the Model 480 which functions to perform.

Below are Model 480 IEEE-488 interface capabilities:

- **SH1:** Source handshake capability.
- **RL1:** Complete remote/local capability.
- **DC1:** Full device clear capability.
- **DT0:** No device trigger capability.
- **C0:** No system controller capability.
- **T5:** Basic TALKER, serial poll capability, talk only, unaddressed to talk if addressed to listen.
- **L4:** Basic LISTENER, unaddressed to listen if addressed to talk.
- **SR1:** Service request capability.
- **AH1:** Acceptor handshake capability.
- **PP0:** No parallel poll capability.
- **E1:** Open collector electronics.

### 6.1.1 IEEE-488 Interface Settings

If using the IEEE-488 interface, you must set the IEEE Address and Terminators. Press the **Interface** key. The first screen selects Serial Interface Baud Rate, and therefore is skipped by pressing the **Enter** key. The Address screen is then displayed.

```
Select With ▲▼
IEEE Address 12
```

Press the ▲ or ▼ keys to increment or decrement the IEEE Address to the desired number. Press **Enter** to accept new number or **Escape** to retain the existing number. Pressing **Enter** displays the Terminators screen.

```
Select With ▲▼
Term Cr Lf
```

Press the ▲ or ▼ keys to cycle through the following Terminator choices: CR/LF, LF/CR, LF, and EOI. To accept changes or the currently displayed setting, push **Enter**. To cancel changes, push **Escape**. Power down the Model 480 then back up again to allow other devices on the IEEE-488 bus to recognize a new Address or Terminator setting.

### 6.1.2 IEEE-488 Command Structure

The Model 480 supports several command types. These commands are divided into three groups.

1. **Bus Control** – refer to Paragraph 6.1.2.1.
  - a. **Universal**
    - (1) Uniline
    - (2) Multiline
  - b. **Addressed Bus Control**
2. **Common** – refer to Paragraph 6.1.2.2.
3. **Interface and Device Specific** – refer to Paragraph 6.1.2.3.

#### 6.1.2.1 Bus Control Commands

A Universal Command addresses all devices on the bus. Universal Commands include Uniline and Multiline Commands. A Uniline Command (Message) asserts only a single signal line. The Model 480 recognizes two of these messages from the BUS CONTROLLER: **Remote (REN)** and **Interface Clear (IFC)**. The Model 480 sends one Uniline Command: **Service Request (SRQ)**.

**REN (Remote)** – Puts the Model 480 into remote mode.

**IFC (Interface Clear)** – Stops current operation on the bus.

**SRQ (Service Request)** – Tells the bus controller that the Model 480 needs interface service.

A Multiline Command asserts a group of signal lines. All devices equipped to implement such commands do so simultaneously upon command transmission. These commands transmit with the Attention (ATN) line asserted low. The Model 480 recognizes two Multiline commands:

**LLO (Local Lockout)** – Prevents the use of instrument front panel controls.

**DCL (Device Clear)** – Clears Model 480 interface activity and puts it into a bus idle state.

### Bus Control Commands (Continued)

Finally, Addressed Bus Control Commands are Multiline commands that must include the Model 480 listen address before the instrument responds. Only the addressed device responds to these commands. The Model 480 recognizes three of the Addressed Bus Control Commands:

**SDC (Selective Device Clear)** – The SDC command performs essentially the same function as the DCL command except that only the addressed device responds.

**GTL (Go To Local)** – The GTL command is used to remove instruments from the remote mode. With some instruments, GTL also unlocks front panel controls if they were previously locked out with the LLO command.

**SPE (Serial Poll Enable)** and **SPD (Serial Poll Disable)** – Serial polling accesses the Service Request (SRQ) Status Register. This status register contains important operational information from the unit requesting service. The SPD command ends the polling sequence.

#### 6.1.2.2 Common Commands

Common Commands are addressed commands which create commonality between instruments on the bus. All instruments that comply with the IEEE-488 1987 standard share these commands and their format. Common commands all begin with an asterisk. They generally relate to “bus” and “instrument” status and identification. Common query commands end with a question mark (?). Refer to Paragraph 6.3 for a list of all Model 480 common commands.

#### 6.1.2.3 Interface and Device Specific Commands

Device Specific Commands are addressed commands. The Model 480 supports a variety of Device Specific commands to program instruments remotely from a digital computer and to transfer measurements to the computer. Most Device Specific Commands perform functions also performed from the front panel. This section discusses Common and Device Specific commands. Device Specific Commands consist of Interface, Display, Channel, and Control Process commands. Refer to Paragraph 6.3 for a list of all Model 480 interface and device specific commands.

### 6.1.3 Status Registers

There are two status registers: the Status Byte Register described in Paragraph 6.1.3.1, and the Standard Event Status Register in Paragraph 6.1.3.2.

#### 6.1.3.1 Status Byte Register and Service Request Enable Register

The Status Byte Register consists of one data byte containing seven bits of information about Model 480 status.

**STATUS BYTE REGISTER FORMAT**

Bit –	7	6	5	4	3	2	1	0
Weighting –	128	64	32	16	8	4	2	1
Bit Name –	Not Used	SRQ	ESB	OVI	AAF	ALM	AAC	FDR

If the Service Request is enabled, setting any of these bits causes the Model 480 to pull the SRQ management low to signal the BUS CONTROLLER. These bits reset to zero upon a serial poll of the Status Byte Register. Inhibit or enable these reports by turning their corresponding bits off or on in the Service Request Enable Register. The \*SRE command sets the bits. Setting a bit in the Service Request Enable Register, enables that function. Refer to the \*SRE command.

**Service Request (SRQ) Bit (6)** – Determines whether the Model 480 reports via the SRQ line. Six bits determine which status reports to make. If bits 0, 1, 2, 3, 4, and/or 5 are set, then the corresponding bit in the Status Byte Register is set. The Model 480 produces a service request only if bit 6 of the Service Request Enable Register is set. If disabled, the BUS CONTROLLER still examines Status Byte Register status reports by serial poll (SPE), but the Service Request cannot interrupt the BUS CONTROLLER. The \*STB common command reads the Status Byte Register but will not clear the bits.

**Bus Control Commands (Continued)**

Below are Status Byte Register bit assignments. These reports occur only if enabled in the Service Request Enable Register.

**Standard Event Status (ESB) Bit (5)** – When set, indicates if one of the bits from the Standard Event Status Register has been set. Refer to Paragraph 6.1.3.2.

**Overload Indicator (OVI) Bit (4)** – When set, indicates a display overload condition. Issues a Service Request if enabled.

**Auto Adjust Fail (AAF) Bit (3)** – When set, the Auto adjustment has failed. This can occur if the drift rate of the instrument is greater than what can be adjusted for. If this bit is set, then the **AAC** bit will be set as well.

**Alarm (ALM) Bit (2)** – When set, an alarm condition exists. This condition latches until acknowledged by the bus controller.

**Auto Adjust Complete (AAC) Bit (1)** – When set, the Auto Drift adjustment has been completed. This bit will be set even if the Auto Drift adjustment fails. Refer to the **AAF** bit above.

**Field Data Ready (FDR) Bit (0)** – When set, new valid field readings are available.

**6.1.3.2 Standard Event Status Register and Standard Event Status Enable Register**

The Standard Event Status Register supplies various conditions of the Model 480.

**STANDARD EVENT STATUS REGISTER FORMAT**

Bit –	7	6	5	4	3	2	1	0
Weighting –	128	64	32	16	8	4	2	1
Bit Name –	PON	Not Used	CME	EXE	DDE	QYE	Not Used	OPC

Bits 2 and 6 are not used. Reports of this register interrupt the user only if the bits are enabled in the Standard Event Status Enable Register and if bit 5 of the Service Request Enable Register is set.

The Standard Event Status Enable Register allows the user to enable any of the Standard Event Status Register reports. The Standard Event Status Enable command (\*ESE) sets the Standard Event Status Enable Register bits. Setting a bit of this register, enables that function. To set a bit, send the command \*ESE with the sum of the bit weighting for each bit to be set. Refer to the \*ESE command.

The Standard Event Status Enable Query, \*ESE?, reads the Standard Event Status Enable Register. \*ESR? reads the Standard Event Status Register. Once this register is read, the bits reset to zero.

**Power On (PON) Bit (7)** – Set to indicate a controller off-on-off transition.

**Command Error (CME) Bit (5)** – Set to indicate a command error since the last reading. Controller unable to interpret a command due to syntax error, unrecognized header or terminators, or unsupported command.

**Execution Error (EXE) Bit (4)** – Set to indicate an execution error. This occurs when the controller is instructed to do something not within its capabilities.

**Device Dependent Error (DDE) Bit (3)** – Set to indicate a device dependent error. Determine the actual device dependent error by executing the various device dependent queries.

**Query Error (QYE) Bit (2)** – Set to indicate a query error. Occurs rarely, but involves data loss due to full output queue.

**Operation Complete (OPC) Bit (0)** – This bit is generated in response to the \*OPC common command. It indicates when the Model 480 has completed all selected pending operations.

## 6.1.4 Example IEEE Setup and Program

Below is an example of how to setup and run a simple program using the built-in Model 480 IEEE-488 Interface. It does not reflect every hardware/software configuration found in the field. This example uses the National Instruments GPIB - PCII/IIA card and QuickBasic 4.0 or 4.5 on a PC compatible.

### 6.1.4.1 GPIB Board Installation

1. Install GPIB-PCII/IIA card using National Instruments instructions.
2. Install NI-488.2 software (for DOS). Version 2.1.1 was used for the example.
3. Verify that config.sys contains the command: device = \gpib-pc\gpib.com.
4. Reboot the computer.
5. Run IBTEST to test software configuration. Do not install the instrument before running IBTEST.
6. Run IBCONF to configure the GPIB - PCII/IIA board and dev 12. Set the EOS byte to 0AH. See setup in Figure 6-1. IBCONF modifies gpib.com.
7. Connect the instrument to the interface board and power up the instrument. Verify address as 12 and terminators as CR LF.

### 6.1.4.2 Running The Example QuickBasic Program

1. Copy c:\gpib-pc\Qbasic\qbib.obj to the QuickBasic directory (QB4).
2. Change to the QuickBasic directory and type: link /q qbib.obj,,,bqlb4x.lib; where x = 0 for QB4.0 and 5 for QB4.5 This one-time only command produces the library file qbib.qlb. The procedure is found in the National Instruments QuickBasic readme file Readme.qb.
3. Start QuickBasic. Type: qb /l qbib.qlb. Start QuickBasic in this way each time the IEEE interface is used to link in the library file.
4. Create the IEEE example interface program in QuickBasic. Refer to Table 6-1. Name the file "ieeexam.bas" and save.
5. Run the program.

### 6.1.5 Notes On Using the IEEE Interface

- To chain commands or queries together, insert a semi-colon (;) between them. Multiple queries cannot be chained. The Model 480 responds to the last query entered when addressed as a talker.
- Queries generally use the same syntax as an associated setting command followed by a question mark. They most often return the same information that is sent. Some queries have no command form.
- Add a query to the end of a command string to confirm command execution. For example, **UNITS 1;UNITS?** commands the Model 480 to set the display units to V's then return the display units to confirm the change.
- The term **free field** indicates that the decimal point is a floating entity and can be placed at any appropriate place in the string of digits.
- Leading zeros and zeros following a decimal point are unneeded in a command string, but they are sent in response to a query. A leading "+" is not required, but a leading "-" is required.
- **[term]** indicates where the user places terminating characters or where they appear on a returning character string from the Model 480.

Table 6-1. Sample BASIC IEEE-488 Interface Program

```

'      IEEEEXAM.BAS      EXAMPLE PROGRAM FOR IEEE-488 INTERFACE
'
'      This program works with QuickBasic 4.0/4.5 on an IBM PC or compatible.
'
'      The example requires a properly configured National Instruments GPIB-PC2 card. The REM
'      $INCLUDE statement is necessary along with a correct path to the file QBDECL.BAS.
'      CONFIG.SYS must call GPIB.COM created by IBCONF.EXE prior to running Basic. There must
'      be QBIB.QBL library in the QuickBasic Directory and QuickBasic must start with a link
'      to it. All instrument settings are assumed to be defaults: Address 12, Terminators
'      <CR> <LF> and EOI active.
'
'      To use, type an instrument command or query at the prompt. The computer transmits to
'      the instrument and displays any response. If no query is sent, the instrument responds
'      to the last query received. Type "EXIT" to exit the program.
'
'      REM $INCLUDE: 'c:\gpib-pc\qbasic\qbdecl.bas'      'Link to IEEE calls
'      CLS                                              'Clear screen
'      PRINT "IEEE-488 COMMUNICATION PROGRAM"
'      PRINT
'
'      CALL IBFIND("dev12", DEV12%)                    'Open communication at address 12
'      TERM$ = CHR$(13) + CHR$(10)                    'Terminators are <CR><LF>
'
LOOP2: IN$ = SPACE$(2000)                               'Clear for return string
'
'      LINE INPUT "ENTER COMMAND (or EXIT):"; CMD$    'Get command from keyboard
'      CMD$ = UCASE$(CMD$)                             'Change input to upper case
'      IF CMD$ = "EXIT" THEN END                      'Get out on Exit
'      CMD$ = CMD$ + TERM$
'
'      CALL IBWRT(DEV12%, CMD$)                       'Send command to instrument
'
'      CALL IBRD(DEV12%, IN$)                         'Get data back each time
'
'      ENDTEST = INSTR(IN$, CHR$(13))                 'Test for returned string
'      IF ENDTEST > 0 THEN                            'String is present if <CR> is seen
'          IN$ = MID$(IN$, 1, ENDTEST - 1)            'Strip off terminators
'          PRINT "RESPONSE:", IN$                    'Print return string
'      ELSE
'          PRINT "NO RESPONSE"                       'No string present if timeout
'      END IF
'      GOTO LOOP2                                     'Get next command

```

National Instruments	GPIB0 Configuration	GPIB-PC2/2A Ver 2.1
Primary GPIB Address .....	→0	Select the primary GPIB address by using the left and right arrow keys.
Secondary GPIB Address .....	NONE	
Timeout setting .....	10sec	<p>This address is used to compute the talk and listen addresses which identify the board or device on the GPIB. Valid primary addresses range from 0 to 30 (00H to 1EH).</p> <p>* Adding 32 to the primary address forms the Listen Address (LA).</p> <p>* Adding 64 to the primary address forms the Talk Address (TA).</p> <p>EXAMPLE: Selecting a primary address of 10 yields the following:</p> <p>10 + 32 = 42 (Listen address)</p> <p>10 + 64 = 74 (Talk address)</p>
Terminate Read on EOS .....	Yes	
Set EOI with EOS on Writes ..	Yes	
Type of compare on EOS .....	7-Bit	
EOS byte .....	0Ah	
Send EOI at end of Write ....	Yes	
System Controller .....	Yes	
Assert REN when SC .....	No	
Enable Auto Serial Polling ..	No	
Enable CIC Protocol .....	No	
Bus Timing .....	500nsec	
Parallel Poll Duration .....	Default	
Use this GPIB board .....	Yes	
Board Type .....	PCII	
Base I/O Address .....	02B8h	
F1: Help F6: Reset Value F9/Esc: Return to Map Ctl PgUp/PgDn: Next/Prev Board		

National Instruments	DEV12 Configuration	GPIB-PC2/2A Ver 2.1	
Primary GPIB Address .....	→12	Select the primary GPIB address by using the left and right arrow keys.	
Secondary GPIB Address .....	NONE		
Timeout setting .....	10sec	<p>This address is used to compute the talk and listen addresses which identify the board or device on the GPIB. Valid primary addresses range from 0 to 30 (00H to 1EH).</p> <p>* Adding 32 to the primary address forms the Listen Address (LA).</p> <p>* Adding 64 to the primary address forms the Talk Address (TA).</p> <p>EXAMPLE: Selecting a primary address of 10 yields the following:</p> <p>10 + 32 = 42 (Listen address)</p> <p>10 + 64 = 74 (Talk address)</p>	
Serial Poll Timeout .....	1sec		
Terminate Read on EOS .....	Yes		
Set EOI with EOS on Writes ..	Yes		
Type of compare on EOS .....	7-Bit		
EOS byte .....	0Ah		
Send EOI at end of Write ....	Yes		
Enable Repeat Addressing ....	Yes		
F1: Help F6: Reset Value F9/Esc: Return to Map Ctl PgUp/PgDn: Next/Prev Board			

**Figure 6-1. Typical National Instruments GPIB Configuration from IBCONF.EXE**

## 6.2 SERIAL I/O INTERFACE

RS-232C is a standard of the Electronics Industries Association (EIA) and one of the most common interfaces between a computer and electronic equipment. The Customer supplied computer must have a Serial Interface port. The Model 480 Serial Interface complies with the electrical format of the RS-232C Interface Standard. A Serial Interface between the computer and the Model 480 permits remote monitoring and control of Model 480 control functions, which in turn controls Model 480 operation. See Figure 6-2.

The Serial Interface can both transmit and receive information. In transmit (Tx) mode, the instrument converts parallel information to serial and sends it over a cable up to 50 feet long (or longer with proper shielding). In receive (Rx) mode, the instrument converts serial information back to parallel for processing.

Refer to Paragraph 6.2.1 for serial interface hardware configuration and adapters, Paragraph 6.2.2 for serial interface settings, and Paragraph 6.6.3 for a sample BASIC program to establish communications between the computer and the Model 480.

The Serial Interface shares Device Specific commands with the IEEE-488 interface listed in Paragraph 6.3. However, without the advantage of the IEEE-488 Architecture, there are several limitations:

- No Bus Control Commands apply.
- Only \*IDN? and \*RST Common Commands are usable.
- Terminators are fixed to CRLF.
- A query must be added to the end of a command string if the Model 480 must return information. (Over IEEE-488, the last query response is sent when addressed to talk). For example: "UNITS 8;UNITS?" sets the units to gauss and immediately queries unit status.

### 6.2.1 Serial Interface Hardware Configuration

Below is a technical description of the Serial Interface. Table 6-2 lists communication parameters. Terminators are fixed to Carriage Return (CR) and Line Feed (LF). The serial interface connector is a 9-Pin D connector.

**Table 6-2. Serial Interface Specifications**

Transmission	Three-Wire
Connector	9-Pin D Connector
Timing Format	Asynchronous, RS-232C Electrical Format
Transmission Mode	Half Duplex
Baud Rate	300, 1200, or 9600
Bits per Character	1 Start, 7 Data, 1 Parity, and 1 Stop
Parity Type	Odd
Data Interface Levels	Transmits and Receives Using EIA Voltage Levels
Fixed Terminator	CR (0DH) LF (0AH)

### 6.2.2 Serial Interface Settings

To use the Serial Interface, set the Baud rate. Press **Baud** to display the following screen.

```

Select With ▲▼
Baud 3 12 ↗96
    
```

Press the ▲ or ▼ keys to cycle through the choices of 300, 1200, or 9600 Baud. Press **Enter** to accept the new number or **Escape** to keep the existing setting and return to the normal display.

### 6.2.3 Sample BASIC Serial Interface Program

The program in Table 6-4 is a sample interactive serial poll routine for the Model 480 Serial Interface written in QuickBASIC V4.0. The following are typical examples using this BASIC program. Input provided by the user is shown in **bold type**.

ENTER COMMAND? <b>READ?</b>	Reading Query. Unit returns reading in the form $\pm XXX.XX$ .
+001.000E+01	Decimal point placement appropriate to range.
ENTER COMMAND? <b>RNGDC?</b>	DC Range Query. Unit returns appropriate range:
0	0 = 300 mV·s or 1 = 30 mV·s.
ENTER COMMAND? <b>UNITS?</b>	Units Query. Unit an integer from 1 to 11 corresponding to the
1	units being used. In this example, 1 = V·s.
ENTER COMMAND? <b>ACDC?</b>	AC or DC Query. Unit returns appropriate setting:
0	0 = DC, 1 = AC.
ENTER COMMAND? <b>FILT?</b>	Filter Query. Unit returns appropriate setting:
0	0 = Off, 1 = On.
ENTER COMMAND? <b>FILT 1;FILT?</b>	Unit turns the filter On then returns a 1 to verify the change.
1	
ENTER COMMAND?	

### 6.2.4 Notes On Using The Serial Interface

- To chain commands together, insert a semi-colon (;) between them. Multiple queries cannot be chained.
- Queries generally use the same syntax as the associated setting command followed by a question mark. They usually return the same information that is sent.
- Add a query to the end of a command string to confirm command execution. For example, **UNITS 8;UNITS?** commands the Model 480 to set units to gauss then requests the Model 480 return the units to confirm the change.
- A correctly spelled query without a "?", returns nothing. Misspelled commands and queries are ignored
- The term **free field** indicates a decimal point floats and can be placed at any appropriate place in the string of digits.
- Leading zeros and zeros following a decimal point are unneeded in a command string, but they are sent in response to a query. A leading "+" is not required, but a leading "-" is required.
- **[term]** indicates where the user places terminating characters or where they appear on a returning character string from the Model 480.
- The following commands are available only over the computer interface; there are no front panel equivalent commands: **CODE** and **BRIGT**.

Table 6-3. Sample BASIC Serial Interface Program

```

SEREXAM.BAS      EXAMPLE PROGRAM FOR SERIAL INTERFACE
'
' This program works with QuickBasic 4.0/4.5 or Qbasic on an IBM PC or compatible
' with a serial interface. It uses the COM1 communication port at 9600 BAUD. Enter
' an instrument command or query at the prompt. The command transmits to the
' instrument which displays any query response. Type "EXIT" to exit the program.
'
CLS              'Clear screen
PRINT " SERIAL COMMUNICATION PROGRAM"
PRINT
TIMEOUT = 2000   'Read timeout (may need more)
BAUD$ = "9600"
TERM$ = CHR$(13) + CHR$(10) 'Terminators are <CR><LF>
OPEN "COM1:" + BAUD$ + ",O,7,1,RS" FOR RANDOM AS #1 LEN = 256

LOOP1: LINE INPUT "ENTER COMMAND (or EXIT):"; CMD$ 'Get command from keyboard
CMD$ = UCASE$(CMD$) 'Change input to upper case
IF CMD$ = "EXIT" THEN CLOSE #1: END 'Get out on Exit
CMD$ = CMD$ + TERM$
PRINT #1, CMD$; 'Send command to instrument

IF INSTR(CMD$, "?") <> 0 THEN 'Test for query
RS$ = "" 'If query, read response
N = 0 'Clr return string and count

WHILE (N < TIMEOUT) AND (INSTR(RS$, TERM$) = 0) 'Wait for response
IN$ = INPUT$(LOC(1), #1) 'Get one character at a time
IF IN$ = "" THEN N = N + 1 ELSE N = 0 'Add 1 to timeout if no chr
RS$ = RS$ + IN$ 'Add next chr to string
WEND 'Get chrs until terminators

IF RS$ <> "" THEN 'See if return string is empty
RS$ = MID$(RS$, 1, (INSTR(RS$, TERM$) - 1)) 'Strip off terminators
PRINT "RESPONSE:"; RS$ 'Print response to query
ELSE
PRINT "NO RESPONSE" 'No response to query
END IF
END IF 'Get next command
GOTO LOOP1

```

**6.3 IEEE-488/SERIAL INTERFACE COMMAND SUMMARY**

<b>Command</b>	<b>Function</b>	<b>Page</b>	<b>Command</b>	<b>Function</b>	<b>Page</b>
<b>Common Commands</b>					
*CLS	Clear Interface .....	6-12	COILKH?	Query Helmholtz Coil Constant.....	6-19
*ESE	Set Std. Event Status Enable .....	6-12	COILKP	Set Potential Coil Constant .....	6-19
*ESE?	Query Std. Event Status Enable.....	6-12	COILKP?	Query Potential Coil Constant.....	6-19
*ESR?	Query Std. Event Status Register .....	6-12	COILN	Set Coil Number of Turns .....	6-19
*IDN?	Query Identification.....	6-13	COILN?	Query Coil Number of Turns .....	6-19
*OPC	Set Operation Complete .....	6-13	COILNUM	Configure Coil Number Parameter.....	6-19
*OPC?	Query Operation Complete.....	6-13	COILNUM?	Query Coil Number Parameter .....	6-19
*RST	Reset Instrument .....	6-13	COILR	Set Coil Resistance.....	6-19
*SRE	Set Service Request Enable.....	6-13	COILR?	Query Coil Resistance .....	6-20
*SRE?	Query Service Request Enable .....	6-13	COILSAVE	Initiate Coil Save Command .....	6-20
*STB?	Query Status Byte .....	6-14	DACCRS	Set Coarse Drift DAC Value.....	6-20
*TST?	Query Self-Test.....	6-14	DACCRS?	Query Coarse Drift DAC Value .....	6-20
*WAI	Wait-To-Continue.....	6-14	DACFINE	Set Fine Drift DAC Value .....	6-20
<b>Interface Commands</b>					
ADDR	Configure IEEE Address.....	6-14	DACFINE?	Query Fine Drift DAC Value.....	6-20
ADDR?	Query IEEE Address .....	6-14	DCRES	Set DC Resolution.....	6-20
BAUD	Configure Serial Interface Baud Rate.....	6-17	DCRES?	Query DC Resolution .....	6-20
BAUD?	Query Serial Interface Baud Rate .....	6-17	DFLT	Set To Factory Defaults .....	6-21
END	Set EOI Parameter .....	6-21	DRAUTO	Initiate Auto Drift Correction.....	6-21
END?	Query EOI Parameter.....	6-21	DRTHR	Set DriftTrak Threshold Level .....	6-21
MODE	Configure Remote Interface Mode .....	6-23	DRTHR?	Query DriftTrak Threshold Level.....	6-21
MODE?	Query Remote Interface Mode .....	6-23	DRTRAK	Configure DriftTrak Function Off/On .....	6-21
TERM	Set Terminating Character .....	6-26	DRTRAK?	Query DriftTrak Function Off/On .....	6-21
TERM?	Query Terminating Character .....	6-26	FILT	Configure Filter Function Off/On .....	6-22
<b>Device Specific Commands</b>					
ACDC	Configure AC/DC Reading Parameter .....	6-14	FILT?	Query Filter Function Off/On .....	6-22
ACDC?	Query AC/DC Reading Parameter .....	6-14	FNUM	Configure Display Filter Points.....	6-22
ALARM	Configure Alarm Function Off/On .....	6-15	FNUM?	Query Display Filter Points .....	6-22
ALARM?	Query Alarm Function Off/On .....	6-15	FWIN	Configure Display Filter Window.....	6-22
ALMB	Configure Audible Alarm Beeper .....	6-15	FWIN?	Query Display Filter Window.....	6-22
ALMB?	Configure Audible Alarm Beeper .....	6-15	KEY?	Query Keypad Status .....	6-22
ALMH	Set Alarm High Point Value .....	6-15	LOCK	Configure Keypad Lock Function.....	6-22
ALMH?	Query Alarm High Point Value.....	6-15	LOCK?	Query Keypad Lock Function.....	6-23
ALMIO	Configure Alarm Trigger Outside/Inside .....	6-15	OPTIN?	Query Optional Input.....	6-23
ALMIO?	Query Alarm Trigger Outside/Inside .....	6-15	PCTMUL	Set Percent Multiplier Constant .....	6-23
ALML	Set Alarm Low Point Value.....	6-16	PCTMUL?	Query Percent Multiplier Constant .....	6-23
ALML?	Query Alarm Low Point Value .....	6-16	PCTSET	Initiate Set Percent Command .....	6-23
ALMS?	Query Alarm Status .....	6-16	PEAK	Configure Peak Hold Function Off/On .....	6-23
ANOCON	Set Analog Out Control Value .....	6-16	PEAK?	Query Peak Hold Function Off/On .....	6-24
ANOCON?	Query Analog Out Control Value .....	6-16	PEAKM	Configure Peak Hold Mode .....	6-24
ANOH	Set Analog Out High Point Value .....	6-16	PEAKM?	Query Peak Hold Mode.....	6-24
ANOH?	Query Analog Out High Point Value.....	6-16	PKNEG?	Query Negative Peak Reading .....	6-24
ANOL	Set Analog Out Low Point Value .....	6-16	PKPOS?	Query Positive Peak Reading .....	6-24
ANOL?	Query Analog Out Low Point Value.....	6-17	PKRST	Initiate Peak Reset Command .....	6-24
ANOM	Configure Analog Out Mode .....	6-17	PROBE	Set Probe Serial Number and Date .....	6-24
ANOM?	Query Analog Out Mode.....	6-17	PROBE?	Query Probe Serial Number and Date .....	6-24
BRIGT	Set Front Panel Display Brightness.....	6-17	RDRST	Initiate Reading Reset Command .....	6-25
BRIGT?	Query Front Panel Display Brightness .....	6-17	READ?	Query Present Display Reading.....	6-25
CODE	Set Keyboard Lock Code.....	6-17	RELAYH	Configure High Relay Function .....	6-25
CODE?	Query Keyboard Lock Code .....	6-17	RELAYH?	Query High Relay Function .....	6-25
COILA	Set Coil Area.....	6-18	RELAYL	Configure Low Relay Function.....	6-25
COILA?	Query Coil Area .....	6-18	RELAYL?	Query Low Relay Function.....	6-25
COILAN	Set Coil Area Turns .....	6-18	RELAYM	Configure Middle Relay Function.....	6-25
COILAN?	Query Coil Area Turns.....	6-18	RELAYM?	Query Middle Relay Function.....	6-25
COILCAL	Initiate Coil Calibration.....	6-18	RNGAC	Configure AC Range Parameter .....	6-25
COILINR	Configure Input Resistance .....	6-18	RNGAC?	Query AC Range Parameter .....	6-26
COILINR?	Query Input Resistance .....	6-18	RNGDC	Configure DC Range Parameter.....	6-26
COILKH	Set Helmholtz Coil Constant.....	6-18	RNGDC?	Query DC Range Parameter.....	6-26
			RNGMX?	Query Maximum Range Value.....	6-26
			UNITS	Configure Display Units Type .....	6-26
			UNITS?	Query Display Units Type .....	6-26

### 6.3.1 Command List Structure

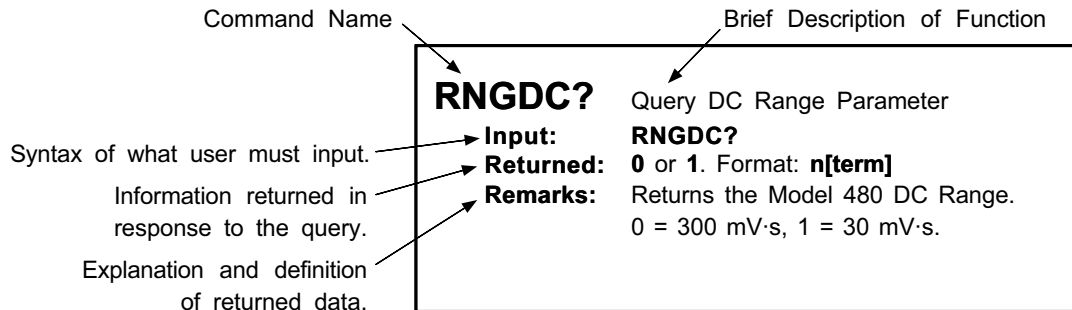

### 6.3.2 IEEE-488/Serial Interface Commands (Alphabetical Listing)

**\*CLS** Clear Interface Command  
**Input:** **\*CLS**  
**Returned:** Nothing.  
**Remarks:** Clears the bits in the Status Byte Register and Standard Event Status Register and terminates all pending operations. Clears the interface, but *not* the instrument. The instrument related command is **\*RST**.

**\*ESE** Configure Status Reports in the Standard Event Status Register  
**Input:** **\*ESE <bit weighting>**  
**Returned:** Nothing.  
**Remarks:** Each bit is assigned a bit weighting and represents the enable/disable status of the corresponding event flag bit in the Standard Event Status Register. To enable an event flag bit, send the command **\*ESE** with the sum of the bit weighting for each desired bit. Refer to the **\*ESR?** command for a list of event flags.  
**Example:** To enable event flags 0, 3, 4, and 7, send the command **\*ESE 143[term]**. 143 is the sum of the bit weighting for each bit.

Bit	Bit Weighting	Event Name
0	1	OPC
3	8	DDE
4	16	EXE
7	128	PON
	143	

**\*ESE?** Query the Configuration of Status Reports in the Standard Event Status Register  
**Input:** **\*ESE?**  
**Returned:** **<ESE bit weighting>**. Format: **nnn[term]**.  
**Remarks:** The integer returned represents the sum of the bit weighting of the enable bits in the Standard Event Status Enable Register. Refer to the **\*ESR?** command for a list of event flags.

**\*ESR?** Query Standard Event Status Register  
**Input:** **\*ESR?**  
**Returned:** **<ESR bit weighting>**. Format: **nnn[term]**.  
**Remarks:** Queries for various Model 480 error conditions and status. The integer returned represents the sum of the bit weighting of the event flag bits in the Standard Event Status Register.

Bit	Bit Weighting	Event Name	Bit	Bit Weighting	Event Name
0	1	OPC	4	16	EXE
2	4	QYE	5	32	CME
3	8	DDE	7	128	PON

**\*IDN?** Query Identification  
**Input:** **\*IDN?**  
**Returned:** <manufacturer>, <model number>, <serial number>, <firmware date>  
 Format: **LSCI,MODEL480,aaaaaa,nnnnnn[term]**.  
**Remarks:** Identifies the instrument model and software level.

**\*OPC** Operation Complete Command  
**Input:** **\*OPC**  
**Returned:** Nothing.  
**Remarks:** Generates an Operation Complete event in the Event Status Register upon completion of all pending selected device operations. Send it as the last command in a command string.

**\*OPC?** Query Operation Complete  
**Input:** **\*OPC?**  
**Returned:** 1. Format: **n[term]**.  
**Remarks:** Places a "1" in the controller output queue upon completion of all pending selected device operations. Send as the last command in a command string. This is *not* the same function as the **\*OPC** command.

**\*RST** Reset Instrument  
**Input:** **\*RST**  
**Returned:** Nothing.  
**Remarks:** Sets controller parameters to power-up settings.

**\*SRE** Configure Status Reports in the Service Request Enable Register  
**Input:** **\*SRE <bit weighting>**  
**Returned:** Nothing.  
**Remarks:** Each bit has a bit weighting and represents the enable/disable status of the corresponding status flag bit in the Status Byte Register. To enable a status flag bit, send the command **\*SRE** with the sum of the bit weighting for each desired bit. Refer to the **\*STB?** command for a list of status flags.  
**Example:** To enable status flags 0, 3, 4, and 6, send the command **\*SRE 89[term]**. 89 is the sum of the bit weighting for each bit.

<u>Bit</u>	<u>Bit Weighting</u>	<u>Event Name</u>
0	1	FDR
3	8	AAF
4	16	OVI
6	64	SRQ
	89	

**\*SRE?** Query the Configuration of Status Reports in the Service Request Enable Register  
**Input:** **\*SRE?**  
**Returned:** <**SRE bit weighting**>. Format: **nnn[term]**.  
**Remarks:** The integer returned represents the sum of the bit weighting of the enabled bits in the Service Request Enable Register. Refer to the **\*STB?** command for a list of status flags.

---

**\*STB?** Query Status Byte  
**Input:** **\*STB?**  
**Returned:** **<STB bit weighting>**. Format: **nnn[term]**.  
**Remarks:** Acts like a serial poll, but does not reset the register to all zeros. The integer returned represents the sum of the bit weighting of the status flag bits that are set in the Status Byte Register.

Bit	Bit Weighting	Event Name	Bit	Bit Weighting	Event Name
0	1	FDR	4	16	OVI
1	2	AAC	5	32	ESB
2	4	ALM	6	64	SRQ
3	8	AAF			

---

**\*TST?** Query Self-Test  
**Input:** **\*TST?**  
**Returned:** **0** or **1**. Format: **n[term]**.  
**Remarks:** The Model 480 performs a self-test at power-up. **0** = no errors found, **1** = errors found.

---

**\*WAI** Wait-to-Continue  
**Input:** **\*WAI**  
**Returned:** Nothing.  
**Remarks:** Prevents execution of any further commands or queries until completion of all previous ones. Changing the sample sensor and reading it immediately with a device dependent query may result in a reading error because the sensor needs time to stabilize. Place a \*WAI between the sensor change and query for a correct reading. Achieve the same results with repeated queries or using a Service Request, but \*WAI is easier.  
  
 Send \*WAI as the last command in a command string followed by appropriate termination. It cannot be embedded between other commands.

---

**ACDC** Configure AC or DC Magnetic Field Reading Parameter.  
**Input:** **ACDC <acdc>**  
**Returned:** Nothing.  
**Remarks:** Configures the unit for AC or DC measurements. **<acdc>** specifies mode. **0** = DC, **1** = AC.

---

**ACDC?** Query AC or DC Magnetic Field Reading Parameter.  
**Input:** **ACDC?**  
**Returned:** **0** or **1**. Format: **n[term]**.  
**Remarks:** Returns the AC or DC measurement mode. **0** = DC, **1** = AC.

---

**ADDR** Configure IEEE Address.  
**Input:** **ADDR <address>**  
**Returned:** Nothing.  
**Remarks:** Configures IEEE address. **<address>** = an integer from **1** to **30**. The Model 480 is factory preset to 12.

---

**ADDR?** Query IEEE Address.  
**Input:** **ADDR?**  
**Returned:** **<address>**. Format: **nn[term]**.  
**Remarks:** Returns the current IEEE address. The Model 480 is factory preset to 12.

---

**ALARM** Configure Alarm Function Off/On.

**Input:** **ALARM <off/on>**

**Returned:** Nothing.

**Remarks:** Configures the alarm function. **0** = Off, **1** = On.

---

**ALARM?** Query Alarm Function Off/On.

**Input:** **ALARM?**

**Returned:** **0** or **1**. Format: **n[term]**.

**Remarks:** Queries the alarm function. **0** = Off, **1** = On.

---

**ALMB** Configure Audible Alarm Beeper.

**Input:** **ALMB <off/on>**

**Returned:** Nothing.

**Remarks:** Configures the audible alarm beeper. **0** = Off, **1** = On.

---

**ALMB?** Query Audible Alarm Beeper.

**Input:** **ALMB?**

**Returned:** **0** or **1**. Format: **n[term]**.

**Remarks:** Queries current audible alarm status. **0** = Off, **1** = On.

---

**ALMH** Set Alarm High Point Value.

**Input:** **ALMH ±nnn.nnnE±nn**

**Returned:** Nothing.

**Remarks:** Sets the high point of the alarm function. Enter up to 6 digits with decimal point in exponential form. Place decimal appropriate to range.

---

**ALMH?** Query Alarm High Point Value.

**Input:** **ALMH?**

**Returned:** **±nnn.nnnE±nn**

**Remarks:** Returns the high point of the alarm function, up to 6 digits with decimal point in exponential form.

---

**ALMIO** Configure Alarm Trigger Outside/Inside.

**Input:** **ALMIO <out/in>**

**Returned:** Nothing.

**Remarks:** Configures the alarm trigger outside/inside function. **0** = Outside, **1** = Inside. This setting determines whether readings inside or outside the defined magnetic field range trigger the alarm.

---

**ALMIO?** Query Alarm Trigger Outside/Inside.

**Input:** **ALMIO?**

**Returned:** **0** or **1**. Format: **n[term]**.

**Remarks:** Queries the alarm trigger inside/outside function: **0** = Outside, **1** = Inside. This setting determines whether readings inside or outside the defined magnetic field range trigger the alarm.

---

**ALML** Set Alarm Low Point Value.  
**Input:** **ALML ±nnn.nnnE±nn**  
**Returned:** Nothing.  
**Remarks:** Sets the low point of the alarm function. Enter up to 6 digits with decimal point in exponential form. Place decimal appropriate to range.

---

**ALML?** Query Alarm Low Point Value.  
**Input:** **ALML?**  
**Returned:** **±nnn.nnnE±nn**  
**Remarks:** Returns the low point of the alarm function, up to 6 digits with decimal point in exponential form.

---

**ALMS?** Query Alarm Status.  
**Input:** **ALMS?**  
**Returned:** **<alarming>, <high status>, <low status>**. Format: **n,n,n[term]**.  
**Remarks:** Queries alarm status. **0** = Off, no alarm exists; **1** = On, alarm exists.

---

**ANOCN** Set Analog Out Control Value.  
**Input:** **ANOCN ±nnn.nnnE±nn**  
**Returned:** Nothing.  
**Remarks:** Sets the percentage of full scale of the analog output in manual mode. Enter up to 6 digits and a decimal point in exponential form. Valid values are from **+100%** to **-100%**.

---

**ANOCN?** Query Analog Out Control Value.  
**Input:** **ANOCN?**  
**Returned:** **±nnn.nnnE±nn**  
**Remarks:** Returns the percentage of full scale of the analog output in manual mode, up to 6 digits and a decimal point in exponential form.

---

**ANOH** Set Analog Out High Point Value.  
**Input:** **ANOH ±nnn.nnnE±nn**  
**Returned:** Nothing.  
**Remarks:** Sets the high point of the analog out function in user mode. Enter up to 6 digits with decimal point in exponential form. Place decimal appropriate to range.

---

**ANOH?** Query Analog Out High Point Value.  
**Input:** **ANOH?**  
**Returned:** **±nnn.nnnE±nn**  
**Remarks:** Returns the high point of the analog out function in user mode, up to 6 digits with decimal point in exponential form.

---

**ANOL** Set Analog Out Low Point Value.  
**Input:** **ANOL ±nnn.nnnE±nn**  
**Returned:** Nothing.  
**Remarks:** Sets the low point of the analog out function in user mode. Enter up to 6 digits with decimal point in exponential form. Place decimal appropriate to range.

---

**ANOL?** Query Analog Out Low Point Value.  
**Input:** **ANOL?**  
**Returned:**  $\pm nnn.nnnE\pm nn$   
**Remarks:** Returns the low point of the analog out function in user mode, up to 6 digits with decimal point in exponential form.

---

**ANOM** Configure Analog Out Mode.  
**Input:** **ANOM <mode>**  
**Returned:** Nothing.  
**Remarks:** Configures analog out mode. **0** = Default, **1** = User, **2** = Manual.

---

**ANOM?** Query Analog Out Mode.  
**Input:** **ANOM?**  
**Returned:** **0, 1, or 2.** Format: **n[term]**.  
**Remarks:** Queries analog out mode: **0** = Default, **1** = User, **2** = Manual.

---

**BAUD** Configure Serial Interface Baud Rate.  
**Input:** **BAUD <bps>**  
**Returned:** Nothing.  
**Remarks:** Configures the serial interface baud rate. **<bps>** specifies bits per second (bps) rate. **0** = 300, **1** = 1200, **2** = 9600.

---

**BAUD?** Query Serial Interface Baud Rate.  
**Input:** **BAUD?**  
**Returned:** **<bps>**. Format: **n[term]**.  
**Remarks:** Returns serial interface baud rate. Refer to BAUD command for parameter descriptions.

---

**BRIGT** Set Front Panel Display Brightness.  
**Input:** **BRIGT <bright>**  
**Returned:** Nothing.  
**Remarks:** Sets the front panel display brightness. **0** = 25%, **1**=50%, **2**=75%, **3**=100%. Default = **2**.

---

**BRIGT?** Query Front Panel Display Brightness.  
**Input:** **BRIGT?**  
**Returned:** **0, 1, 2, or 3.** Format: **n[term]**.  
**Remarks:** Queries the front panel display brightness. **0** = 25%, **1**=50%, **2**=75%, **3**=100%. Default = **2**.

---

**CODE** Set Front Panel Keyboard Lock Code.  
**Input:** **CODE XXX**  
**Returned:** Nothing.  
**Remarks:** Sets front panel keyboard lock code: Default = **123**. Enter any three numbers.

---

**CODE?** Front Panel Keyboard Lock Code Query.  
**Input:** **CODE?**  
**Returned:** **XXX**  
**Remarks:** Returns the 3 numbers that comprise the front panel keyboard lock code.

---

---

<b>COILA</b>	Set Coil Area. <b>Input:</b> <b>COILA ±nnn.nnnE±nn</b> <b>Returned:</b> Nothing. <b>Remarks:</b> Sets coil area for current coil in units of cm <sup>2</sup> . Enter up to 6 digits and a decimal point in exponential form.
--------------	---

---

<b>COILA?</b>	Query Coil Area. <b>Input:</b> <b>COILA?</b> <b>Returned:</b> ±nnn.nnnE±nn <b>Remarks:</b> Returns coil area for current coil in units of cm <sup>2</sup> . Returns up to 6 digits and a decimal point in exponential form.
---------------	--

---

<b>COILAN</b>	Set Coil Area·Turns. <b>Input:</b> <b>COILAN ±nnn.nnnE±nn</b> <b>Returned:</b> Nothing. <b>Remarks:</b> Sets coil area·turns for current coil in units of cm <sup>2</sup> . Enter up to 6 digits and a decimal point in exponential form.
---------------	--

---

<b>COILAN?</b>	Query Coil Area·Turns. <b>Input:</b> <b>COILAN?</b> <b>Returned:</b> ±nnn.nnnE±nn <b>Remarks:</b> Returns coil area·turns for current coil in units of cm <sup>2</sup> . Returns up to 6 digits and a decimal point in exponential form.
----------------	---

---

<b>COILCAL</b>	Initiate Coil Calibration. <b>Input:</b> <b>COILCAL ±nnn.nnnE±nn</b> <b>Returned:</b> Nothing. <b>Remarks:</b> Calibrates the attached coil using the currently measured field. This command only works in units of Vφ, Wbφ, Mxφ, T, G, Wb·cm, or A. The number part of the command is the value of the known field that is being used to calibrate the coil. The coil must be in the field when the command is issued.
----------------	--

---

<b>COILINR</b>	Configure Input Resistance. <b>Input:</b> <b>COILINR &lt;resistance&gt;</b> <b>Returned:</b> Nothing. <b>Remarks:</b> Configures the input resistance. <b>0</b> = 0Ω input, <b>1</b> = 10kΩ input, <b>2</b> = 100kΩ input.
----------------	---

---

<b>COILINR?</b>	Query Input Resistance. <b>Input:</b> <b>COILINR?</b> <b>Returned:</b> <b>0, 1, or 2.</b> Format: <b>n[term]</b> . <b>Remarks:</b> Queries the input resistance. <b>0</b> = 0Ω input, <b>1</b> = 10kΩ input, <b>2</b> = 100kΩ input.
-----------------	---

---

<b>COILKH</b>	Set Helmholtz Coil Constant. <b>Input:</b> <b>COILKH ±nnn.nnnE±nn</b> <b>Returned:</b> Nothing. <b>Remarks:</b> Sets Helmholtz coil constant for current coil in units of cm. Enter up to 6 digits and a decimal point in exponential form.
---------------	--

---

**COILKH?** Query Helmholtz Coil Constant.

**Input:** **COILKH?**

**Returned:**  $\pm nnn.nnnE\pm nn$

**Remarks:** Returns Helmholtz coil constant for current coil in units of cm. Returns up to 6 digits and a decimal point in exponential form.

---

**COILKP** Set Potential Coil Constant.

**Input:** **COILKP  $\pm nnn.nnnE\pm nn$**

**Returned:** Nothing.

**Remarks:** Sets potential coil constant for current coil in units of A/V-s. Enter up to 6 digits and a decimal point in exponential form.

---

**COILKP?** Query Potential Coil Constant.

**Input:** **COILKP?**

**Returned:**  $\pm nnn.nnnE\pm nn$

**Remarks:** Returns potential coil constant for current coil in units of A/V-s. Returns up to 6 digits and a decimal point in exponential form.

---

**COILN** Set Coil Number Of Turns.

**Input:** **COILN  $\pm nnn.nnnE\pm nn$**

**Returned:** Nothing.

**Remarks:** Sets number of turns for current coil in units of turns. Enter up to 6 digits and a decimal point in exponential form.

---

**COILN?** Query Coil Number Of Turns.

**Input:** **COILN?**

**Returned:**  $\pm nnn.nnnE\pm nn$

**Remarks:** Returns number of turns for current coil in units of turns. Returns up to 6 digits and a decimal point in exponential form.

---

**COILNUM** Configure Coil Number Parameter.

**Input:** **COILNUM <coil number>**

**Returned:** Nothing.

**Remarks:** Configures unit for a set of stored coil parameters. **1 - 10** = internally stored coil parameters, **11** = probe data.

---

**COILNUM?** Query Coil Number Parameter.

**Input:** **COILNUM?**

**Returned:** An integer from **0** to **11**. Format: **nn[term]**.

**Remarks:** Returns the number of the coil parameters currently loaded. **0** = user coil (modified coil), **1 - 10** = internally stored coil parameters, **11** = probe data.

---

**COILR** Set Coil Resistance.

**Input:** **COILR  $\pm nnn.nnnE\pm nn$**

**Returned:** Nothing.

**Remarks:** Sets coil resistance for current coil in units of ohms ( $\Omega$ ). This is the DC resistance of the coil itself. Enter up to 6 digits and a decimal point in exponential form.

---

---

<b>COILR?</b>	Query Coil Resistance.
<b>Input:</b>	<b>COILR?</b>
<b>Returned:</b>	$\pm nnn.nnnE\pm nn$
<b>Remarks:</b>	Returns coil resistance for current coil in units of ohms ( $\Omega$ ). This is the DC resistance of the coil itself. Returns up to 6 digits and a decimal point in exponential form.

---

<b>COILSAVE</b>	Initiate Coil Save Command.
<b>Input:</b>	<b>COILSAVE &lt;coil number&gt;</b>
<b>Returned:</b>	Nothing.
<b>Remarks:</b>	Saves the current coil parameters to a coil location. <b>1 - 10</b> = internally stored coil parameters, <b>11</b> = probe data. Any previous information in the coil location will be overwritten. A probe with a PROM attachment (Lake Shore Part Number FCBL-6) is required to write to probe data (coil number 11).

---

<b>DACCRS</b>	Set Coarse Drift Adjustment DAC Value.
<b>Input:</b>	<b>DACCRS <math>\pm nnn.nnnE\pm nn</math></b>
<b>Returned:</b>	Nothing.
<b>Remarks:</b>	Sets the percentage of full scale of the coarse drift adjustment DAC. Enter up to 6 digits and a decimal point in exponential form. Valid values are from <b>+100%</b> to <b>-100%</b> .

---

<b>DACCRS?</b>	Query Coarse Drift Adjustment DAC Value.
<b>Input:</b>	<b>DACCRS?</b>
<b>Returned:</b>	$\pm nnn.nnnE\pm nn$
<b>Remarks:</b>	Returns the percentage of full scale of the coarse drift adjustment DAC, up to 6 digits and a decimal point in exponential form.

---

<b>DACFINE</b>	Set Fine Drift Adjustment DAC Value.
<b>Input:</b>	<b>DACFINE <math>\pm nnn.nnnE\pm nn</math></b>
<b>Returned:</b>	Nothing.
<b>Remarks:</b>	Sets the percentage of full scale of the fine drift adjustment DAC. Enter up to 6 digits and a decimal point in exponential form. Valid values are from <b>+100%</b> to <b>-100%</b> .

---

<b>DACFINE?</b>	Query Fine Drift Adjustment DAC Value.
<b>Input:</b>	<b>DACFINE?</b>
<b>Returned:</b>	$\pm nnn.nnnE\pm nn$
<b>Remarks:</b>	Returns the percentage of full scale of the fine drift adjustment DAC, up to 6 digits and a decimal point in exponential form.

---

<b>DCRES</b>	Set DC Resolution High/Low
<b>Input:</b>	<b>DCRES</b>
<b>Returned:</b>	Nothing.
<b>Remarks:</b>	Sets the DC Resolution of the unit, where 0 = 5 $\frac{3}{4}$ digits and 1 = 4 $\frac{3}{4}$ digits.

---

<b>DCRES?</b>	Query DC Resolution High/Low
<b>Input:</b>	<b>DCRES?</b>
<b>Returned:</b>	<b>0</b> , or <b>1</b> . Format: <b>n[term]</b> .
<b>Remarks:</b>	Returns the DC Resolution of the unit, where 0 = 5 $\frac{3}{4}$ digits and 1 = 4 $\frac{3}{4}$ digits.

---

<b>DFLT 99</b>	Set To Factory Defaults.
<b>Input:</b>	<b>DFLT 99</b>
<b>Returned:</b>	Nothing.
<b>Remarks:</b>	Used to reset the instrument to default values and to clear the user-entered coil parameters. Does not clear instrument calibration.
<b>DRAUTO</b>	Initiate Auto Drift Correction.
<b>Input:</b>	<b>DRAUTO</b>
<b>Returned:</b>	Nothing.
<b>Remarks:</b>	Starts an Auto Drift Correction. Sets Fine DAC to 0 and adjusts Coarse DAC. This process takes approximately 25 seconds to complete.
<b>DRTHR</b>	Set DriftTrak Threshold Level.
<b>Input:</b>	<b>DRTHR nnnn</b>
<b>Returned:</b>	Nothing.
<b>Remarks:</b>	Sets the threshold level of the DriftTrak function. This is the rate of change that will cause the DriftTrak function to stop adjusting the DACs. Too small a value and DriftTrak will never engage. Too large a value and DriftTrak will mistake a measurement signal for drift. The number is a 4-digit integer and the units are $\mu\text{V}\cdot\text{s}/\text{min}$ . The default setting is 200 $\mu\text{V}\cdot\text{s}/\text{min}$ .
<b>DRTHR?</b>	Query DriftTrak Threshold Level.
<b>Input:</b>	<b>DRTHR?</b>
<b>Returned:</b>	<b>nnnn</b>
<b>Remarks:</b>	Queries the threshold level of the DriftTrak function. This is the rate of change that will cause the DriftTrak function to stop adjusting the DACs. The number returned is a 4-digit integer and is the units of $\mu\text{V}\cdot\text{s}/\text{min}$ .
<b>DRTRAK</b>	Configure DriftTrak Function Off/On.
<b>Input:</b>	<b>DRTRAK &lt;off/on&gt;</b>
<b>Returned:</b>	Nothing.
<b>Remarks:</b>	Configures the DriftTrak function. <b>0</b> = Off, <b>1</b> = On. The DriftTrak function continuously adjusts the drift correction DACs when the instrument is not taking a measurement to minimize drift.
<b>DRTRAK?</b>	Query DriftTrak Function Off/On.
<b>Input:</b>	<b>DRTRAK?</b>
<b>Returned:</b>	<b>0</b> or <b>1</b> . Format: <b>n[term]</b> .
<b>Remarks:</b>	Queries the DriftTrak function. <b>0</b> = Off, <b>1</b> = On.
<b>END</b>	Set End Or Identify (EOI) Parameter.
<b>Input:</b>	<b>END &lt;EOI enable&gt;</b>
<b>Returned:</b>	Nothing.
<b>Remarks:</b>	Sets the EOI parameter. <b>&lt;EOI enable&gt;</b> enables/disables EOI, <b>0</b> = enabled, <b>1</b> = disabled. When enabled, the hardware EOI line becomes active with the last byte of a transfer. The EOI identifies the last byte allowing for variable length data transmissions.
<b>END?</b>	Query End Or Identify (EOI) Parameter.
<b>Input:</b>	<b>END?</b>
<b>Returned:</b>	<b>0</b> or <b>1</b> . Format: <b>n[term]</b> .
<b>Remarks:</b>	Returns EOI parameter. <b>0</b> = EOI enabled, <b>1</b> = EOI disabled.

---

<b>FILT</b>	Configure Display Filter Function Off/On. <b>Input:</b> <b>FILT &lt;off/on&gt;</b> <b>Returned:</b> Nothing. <b>Remarks:</b> Configures the display filter function. <b>0</b> = Off, <b>1</b> = On. Quiets the display reading by a degree depending on the points ( <b>FNUM</b> ) and window ( <b>FWIN</b> ) settings.
<b>FILT?</b>	Query Display Filter Function Off/On. <b>Input:</b> <b>FILT?</b> <b>Returned:</b> <b>0</b> or <b>1</b> . Format: <b>n[term]</b> . <b>Remarks:</b> Queries the display filter function. <b>0</b> = Off, <b>1</b> = On. Quiets the display reading by a degree depending on the points ( <b>FNUM</b> ) and window ( <b>FWIN</b> ) settings.
<b>FNUM</b>	Configure Display Filter Points. <b>Input:</b> <b>FNUM &lt;points&gt;</b> <b>Returned:</b> Nothing <b>Remarks:</b> Configures the display filter points: <b>&lt;points&gt;</b> = integers 2 thru 64. In general, the higher the number, the longer the display settle time.
<b>FNUM?</b>	Query Display Filter Points. <b>Input:</b> <b>FNUM?</b> <b>Returned:</b> <b>&lt;points&gt;</b> . Format: <b>nn[term]</b> . <b>Remarks:</b> Queries the display filter points. <b>&lt;points&gt;</b> = integers 2 thru 64. In general, the higher the number, the longer the display settle time.
<b>FWIN</b>	Configure Display Filter Window. <b>Input:</b> <b>FWIN &lt;window&gt;</b> <b>Returned:</b> Nothing. <b>Remarks:</b> Configures the display filter window. <b>&lt;window&gt;</b> = 1% thru 10%. The smaller the percentage, the smaller the change in reading that causes the filter to restart. Refer to Paragraph 5.12.
<b>FWIN?</b>	Query Display Filter Window. <b>Input:</b> <b>FWIN?</b> <b>Returned:</b> <b>&lt;window&gt;</b> . Format: <b>nn[term]</b> . <b>Remarks:</b> Queries the display filter window. <b>&lt;window&gt;</b> = 1% thru 10%. The smaller the percentage, the smaller the change in reading that causes the filter to restart. Refer to Paragraph 5.12.
<b>KEY?</b>	Query Keypad Status. <b>Input:</b> <b>KEY?</b> <b>Returned:</b> <b>0</b> or <b>1</b> . Format: <b>n[term]</b> . <b>Remarks:</b> Queries if a key was pressed or power was cycled since the last <b>KEY?</b> query. <b>0</b> = no key pressed, <b>1</b> = key pressed.
<b>LOCK</b>	Configure Front Panel Keypad Lock Function. <b>Input:</b> <b>LOCK &lt;off/on&gt;</b> <b>Returned:</b> Nothing. <b>Remarks:</b> Configures the front panel keypad lock function. <b>0</b> = Unlocked, <b>1</b> = Locked.

---

---

<b>LOCK?</b>	Query Front Panel Keypad Lock Function.
<b>Input:</b>	<b>LOCK?</b>
<b>Returned:</b>	<b>0</b> or <b>1</b> . Format: <b>n[term]</b> .
<b>Remarks:</b>	Queries the front panel keypad lock function. <b>0</b> = Unlocked, <b>1</b> = Locked.

---

<b>MODE</b>	Configure Remote Interface Mode.
<b>Input:</b>	<b>MODE &lt;mode&gt;</b> .
<b>Returned:</b>	Nothing.
<b>Remarks:</b>	Configures the remote interface mode. <b>&lt;mode&gt;</b> specifies which mode to operate. <b>0</b> = local, <b>1</b> = remote, <b>2</b> = remote with local lockout. Press the front panel <b>Local</b> key to set the Model 480 to local provided the key has not been disabled by local lockout. The Model 480 powers up in local mode.

---

<b>MODE?</b>	Query Remote Interface Mode.
<b>Input:</b>	<b>MODE?</b>
<b>Returned:</b>	<b>&lt;mode&gt;</b> . Format: <b>n[term]</b> .
<b>Remarks:</b>	Returns the remote interface mode. <b>0</b> = local, <b>1</b> = remote, <b>2</b> = remote with local lockout.

---

<b>OPTIN?</b>	Query Optional Input.
<b>Input:</b>	<b>OPTIN?</b>
<b>Returned:</b>	<b>0</b> or <b>1</b> . Format: <b>n[term]</b> .
<b>Remarks:</b>	Queries the optional input on the rear panel. <b>0</b> = open or logic high, <b>1</b> = shorted or logic low.

---

<b>PCTMUL</b>	Set Percent Multiplier Constant.
<b>Input:</b>	<b>PCTMUL ±nnn.nnnE±nn</b>
<b>Returned:</b>	Nothing.
<b>Remarks:</b>	Sets the percent multiplier used to calculate units of percent. Enter up to 6 digits and a decimal point in exponential form.

---

<b>PCTMUL?</b>	Query Percent Multiplier Constant.
<b>Input:</b>	<b>PCTMUL?</b>
<b>Returned:</b>	<b>±nnn.nnnE±nn</b>
<b>Remarks:</b>	Returns the percent multiplier constant used to calculate units of percent. Returns up to 6 digits and a decimal point in exponential form.

---

<b>PCTSET</b>	Initiate Set Percent Command.
<b>Input:</b>	<b>PCTSET ±nnn.nnnE±nn</b>
<b>Returned:</b>	Nothing.
<b>Remarks:</b>	Recalculates a percent multiplier for the currently measured field. The number part of the command is the desired reading value of the current field. The coil must be in the field when the command is issued.
<b>Example:</b>	<b>PCTSET 50.00[term]</b> : Equates a display of 50% with the current reading. Anytime the reading equals the current reading, a value of 50% displays.

---

<b>PEAK</b>	Configure Peak Hold Function Off/On.
<b>Input:</b>	<b>PEAK &lt;off/on&gt;</b>
<b>Returned:</b>	Nothing.
<b>Remarks:</b>	Configures the peak hold function. <b>0</b> = Normal reading, <b>1</b> = Peak hold.

---

---

<b>PEAK?</b>	Query Peak Hold Function Off/On. <b>Input:</b> <b>PEAK?</b> <b>Returned:</b> <b>0</b> or <b>1</b> . Format: <b>n[term]</b> . <b>Remarks:</b> Queries the peak hold function. <b>0</b> = Normal reading, <b>1</b> = Peak hold.
<b>PEAKM</b>	Configure Peak Hold Mode. <b>Input:</b> <b>PEAKM &lt;mode&gt;</b> <b>Returned:</b> Nothing. <b>Remarks:</b> Configures the peak hold mode. <b>0</b> = Positive peak, <b>1</b> = Negative peak, <b>2</b> = Both positive and negative peaks. Capturing both peaks decreases sampling frequency by a factor of 4.
<b>PEAKM?</b>	Query Peak Hold Mode. <b>Input:</b> <b>PEAKM?</b> <b>Returned:</b> <b>0</b> , <b>1</b> , or <b>2</b> . Format: <b>n[term]</b> . <b>Remarks:</b> Queries the peak hold mode. <b>0</b> = Positive peak, <b>1</b> = Negative peak, <b>2</b> = Both positive and negative peaks. Capturing both peaks decreases sampling frequency by a factor of 4.
<b>PKNEG?</b>	Query Negative Peak Reading. <b>Input:</b> <b>PKNEG?</b> <b>Returned:</b> $\pm nn.nnnE\pm nn$ <b>Remarks:</b> Returns current negative peak reading in exponential form in the currently selected units.
<b>PKPOS?</b>	Query Positive Peak Reading. <b>Input:</b> <b>PKPOS?</b> <b>Returned:</b> $\pm nn.nnnE\pm nn$ <b>Remarks:</b> Returns current positive peak reading in exponential form in the currently selected units.
<b>PKRST</b>	Initiate Peak Reset Command. <b>Input:</b> <b>PKRST</b> <b>Returned:</b> Nothing. <b>Remarks:</b> Resets the peak hold circuit and the peak hold values.
<b>PROBE</b>	Set Probe Serial Number and Date. <b>Input:</b> <b>PROBE &lt;serial number&gt;,&lt;date&gt;</b> <b>Returned:</b> Nothing. <b>Remarks:</b> Sets the serial number and date for the attached probe. A probe with a PROM attachment (Lake Shore part #FCBL-6) is required for this function. Enter up to 10 characters for a serial number and enter a date in the form <b>mmddyyyy</b> (month, day, year). This command does not save the information to the probe itself. The COILSAVE command must be used to save the serial number, date, and coil parameters to the probe. <b>Example:</b> <b>PROBE User 5,12291998</b> sets the serial number to User 5 and the date to 12/29/1998.
<b>PROBE?</b>	Query Probe Serial Number and Date. <b>Input:</b> <b>PROBE?</b> <b>Returned:</b> <b>&lt;serial number&gt;,&lt;date&gt;</b> . Format: <b>aaaaaaaaa,nnnnnnnn</b> . <b>Remarks:</b> Returns the serial number and date for the probe attached during power up. If a new probe is attached, cycle the power to load new probe data. A probe with a PROM attachment (Lake Shore part #FCBL-6) or a Lake Shore probe is required for this function. Returns 10 characters for a serial number and returns a date in the form <b>mmddyyyy</b> (month, day, year).

---

---

<b>RDRST</b>	Initiate Reading Reset Command.
<b>Input:</b>	<b>RDRST</b>
<b>Returned:</b>	Nothing.
<b>Remarks:</b>	In DC mode, resets the reading of the unit to zero. Does not function in AC mode.

---

<b>READ?</b>	Query Present Display Reading.
<b>Input:</b>	<b>READ?</b>
<b>Returned:</b>	$\pm nnn.nnnE\pm nn$
<b>Remarks:</b>	Returns the present reading in exponential form in the currently selected units.

---

<b>RELAYH</b>	Configure High Relay Function.
<b>Input:</b>	<b>RELAYH &lt;mode&gt;</b>
<b>Returned:</b>	Nothing.
<b>Remarks:</b>	Configures the high relay function. <b>0</b> = Manual Off, <b>1</b> = Manual On, <b>2</b> = Automatic.

---

<b>RELAYH?</b>	Query High Relay Function.
<b>Input:</b>	<b>RELAYH?</b>
<b>Returned:</b>	<b>0, 1, or 2.</b> Format: <b>n[term]</b> .
<b>Remarks:</b>	Returns the high relay function. <b>0</b> = Manual Off, <b>1</b> = Manual On, <b>2</b> = Automatic.

---

<b>RELAYL</b>	Configure Low Relay Function.
<b>Input:</b>	<b>RELAYL &lt;mode&gt;</b>
<b>Returned:</b>	Nothing.
<b>Remarks:</b>	Configures the low relay function. <b>0</b> = Manual Off, <b>1</b> = Manual On, <b>2</b> = Automatic.

---

<b>RELAYL?</b>	Query Low Relay Function.
<b>Input:</b>	<b>RELAYL?</b>
<b>Returned:</b>	<b>0, 1, or 2.</b> Format: <b>n[term]</b> .
<b>Remarks:</b>	Returns the low relay function. <b>0</b> = Manual Off, <b>1</b> = Manual On, <b>2</b> = Automatic.

---

<b>RELAYM</b>	Configure Middle Relay Function.
<b>Input:</b>	<b>RELAYM &lt;mode&gt;</b>
<b>Returned:</b>	Nothing.
<b>Remarks:</b>	Configures the middle relay function. <b>0</b> = Manual Off, <b>1</b> = Manual On, <b>2</b> = Automatic.

---

<b>RELAYM?</b>	Query Middle Relay Function.
<b>Input:</b>	<b>RELAYM?</b>
<b>Returned:</b>	<b>0, 1, or 2.</b> Format: <b>n[term]</b> .
<b>Remarks:</b>	Returns the middle relay function. <b>0</b> = Manual Off, <b>1</b> = Manual On, <b>2</b> = Automatic.

---

<b>RNGAC</b>	Configure AC Range Parameter.
<b>Input:</b>	<b>RNGAC &lt;range&gt;</b>
<b>Returned:</b>	Nothing
<b>Remarks:</b>	Configures the Model 480 AC range. <b>0</b> = 30 mV·s, <b>1</b> = 3 mV·s, <b>2</b> = 300 $\mu$ V·s, <b>3</b> = 30 $\mu$ V·s.

---

---

<b>RNGAC?</b>	Query AC Range Parameter. <b>Input:</b> <b>RNGAC?</b> <b>Returned:</b> An integer from <b>0</b> to <b>3</b> . Format: <b>n[term]</b> . <b>Remarks:</b> Returns the Model 480 AC range. <b>0</b> = 30 mV·s, <b>1</b> = 3 mV·s, <b>2</b> = 300 $\mu$ V·s, <b>3</b> = 30 $\mu$ V·s.
---------------	---

---

<b>RNGDC</b>	Configure DC Range Parameter. <b>Input:</b> <b>RNGDC &lt;range&gt;</b> <b>Returned:</b> Nothing. <b>Remarks:</b> Configures the Model 480 DC range. <b>0</b> = 300 mV·s, <b>1</b> = 30 mV·s.
--------------	---

---

<b>RNGDC?</b>	Query DC Range Parameter. <b>Input:</b> <b>RNGDC?</b> <b>Returned:</b> <b>0</b> or <b>1</b> . Format: <b>n[term]</b> . <b>Remarks:</b> Returns the Model 480 DC range. <b>0</b> = 300 mV·s, <b>1</b> = 30 mV·s.
---------------	--

---

<b>RNGMX?</b>	Query Maximum Range Value. <b>Input:</b> <b>RNGMX?</b> <b>Returned:</b> $\pm$ nnn.nnnE $\pm$ nn <b>Remarks:</b> Returns the maximum range in the currently selected units. This is the maximum reading the unit can handle on the current range setting.
---------------	---

---

<b>TERM</b>	Set Terminating Character. <b>Input:</b> <b>TERM &lt;terminator&gt;</b> <b>Returned:</b> Nothing. <b>Remarks:</b> Sets the IEEE-488 terminating character type. <b>&lt;terminator&gt;</b> specifies the terminator. <b>0</b> = (CR)(LF), <b>1</b> = (LF)(CR), <b>2</b> = (LF), <b>3</b> = No terminators. Terminating characters are sent when the Model 480 completes its message transfer on output. They also identify the end of an input message. This command works only with the IEEE-488 Interface and does not change the serial terminators.
-------------	---

---

<b>TERM?</b>	Query Terminating Character. <b>Input:</b> <b>TERM?</b> <b>Returned:</b> <b>0</b> , <b>1</b> , <b>2</b> , or <b>3</b> . Format: <b>n[term]</b> . <b>Remarks:</b> Returns the IEEE-488 terminating character type: <b>0</b> = (CR)(LF), <b>1</b> = (LF)(CR), <b>2</b> = (LF), <b>3</b> = No terminators.
--------------	--

---

<b>UNITS</b>	Configure Display Units Type. <b>Input:</b> <b>UNITS &lt;unit number&gt;</b> <b>Returned:</b> Nothing. <b>Remarks:</b> Configures the Model 480 to the units listed below.  <table border="0" style="margin-left: 20px;"> <tr> <td><b>1</b> = V·s (Flux turns)</td> <td><b>5</b> = Wb<math>\phi</math> (Flux)</td> <td><b>9</b> = % (Percent)</td> </tr> <tr> <td><b>2</b> = MxN (Flux turns)</td> <td><b>6</b> = Mx<math>\phi</math> (Flux)</td> <td><b>10</b> = Wb·cm (Magnetic Moment)</td> </tr> <tr> <td><b>3</b> = WbN (Flux turns)</td> <td><b>7</b> = T (Flux density)</td> <td><b>11</b> = A (Magnetic Potential)</td> </tr> <tr> <td><b>4</b> = V·s<math>\phi</math> (Flux)</td> <td><b>8</b> = G (Flux density)</td> <td></td> </tr> </table>	<b>1</b> = V·s (Flux turns)	<b>5</b> = Wb $\phi$ (Flux)	<b>9</b> = % (Percent)	<b>2</b> = MxN (Flux turns)	<b>6</b> = Mx $\phi$ (Flux)	<b>10</b> = Wb·cm (Magnetic Moment)	<b>3</b> = WbN (Flux turns)	<b>7</b> = T (Flux density)	<b>11</b> = A (Magnetic Potential)	<b>4</b> = V·s $\phi$ (Flux)	<b>8</b> = G (Flux density)	
<b>1</b> = V·s (Flux turns)	<b>5</b> = Wb $\phi$ (Flux)	<b>9</b> = % (Percent)											
<b>2</b> = MxN (Flux turns)	<b>6</b> = Mx $\phi$ (Flux)	<b>10</b> = Wb·cm (Magnetic Moment)											
<b>3</b> = WbN (Flux turns)	<b>7</b> = T (Flux density)	<b>11</b> = A (Magnetic Potential)											
<b>4</b> = V·s $\phi$ (Flux)	<b>8</b> = G (Flux density)												

---

<b>UNITS?</b>	Query Display Units Type. <b>Input:</b> <b>UNITS?</b> <b>Returned:</b> An integer from <b>1</b> to <b>11</b> . Format: <b>n[term]</b> . <b>Remarks:</b> Returns current units number. Refer to <b>UNITS</b> command for unit number representations.
---------------	---

---

# CHAPTER 7

## ACCESSORIES, COILS, AND PROBES

### 7.0 GENERAL

This chapter provides information the various accessories, coils, and probes available for the Lake Shore Model 480 Fluxmeter. Accessories are described in Paragraph 7.1, field measuring probes in Paragraph 7.2, Helmholtz coils in Paragraph 7.3, and reference magnets in Paragraph 7.4.

In many cases, Users may mate existing coils and fixtures to the Model 480 Fluxmeter rather than having to purchase new items from Lake Shore. Interfacing is made easy with the simple software functions available.

For those lacking time or technical expertise to make their own coils, Lake Shore offers a line of factory-calibrated coils and probes. Special designs to meet specific applications are also available.

### 7.1 ACCESSORIES

Accessories are devices that perform a secondary duty as an aid or refinement to the primary unit. Accessories available for the Model 480 Fluxmeter are listed as follows.

Model Number	Description
<b>106-739</b>	<b>Terminal Block Mating Connector.</b> Eight pin, quantity of two.
<b>4004</b>	<b>IEEE-488 Interface Cable.</b> Connects Model 480 to Customer-supplied computer with IEEE-488 Interface. Cable is 1 meter (3.3 feet) long.
<b>4030-XX</b>	<p><b>Probe Stand.</b> This moveable probe stand consists of a 30 mm square post mounted on a 180 × 130 × 22.5 mm thick base plate. A probe holder is integrated into the stand. The holder can be moved up or down and fixed at any angle and location along the post. Two models are available as follows. Consult factory for other post heights.</p> <p><b>4030-12</b> Probe stand with 12 inch tall post and probe holder to accept 3/8-inch diameter probe handle.</p> <p><b>4030-24</b> Probe stand with 24 inch tall post and probe holder to accept 3/8-inch diameter probe handle.</p>
<b>FCBL-6</b>	<b>User Programmable Coil Interconnect Cable.</b> Has an internal PROM that is programmable from the Model 480 front panel. 1.8 meters (6 feet) long. Refer to Paragraph 3.5 for installation. Refer to Paragraph 5.6.2 for programming.
<b>FH-XX</b>	<p><b>Helmholtz Coils.</b> Three coils are available as follows. Refer to Paragraph 7.3.</p> <p><b>FH-2.5</b> Helmholtz Coil, 2.5-inch inner diameter, coil resistance: <math>\approx 35 \Omega</math>. See Figure 7-3.</p> <p><b>FH-6</b> Helmholtz Coil, 6-inch inner diameter, coil resistance: <math>\approx 110 \Omega</math>. See Figure 7-4.</p> <p><b>FH-12</b> Helmholtz Coil, 12-inch inner diameter, coil resistance: <math>\approx 140 \Omega</math>. See Figure 7-5.</p>
<b>FNT-6R04-100</b>	<b>Field Probe – 100 cm<sup>2</sup> Area-turns.</b> Refer to Paragraph 7.2.1 and see Figure 7-1.
<b>FNT-5R04-30</b>	<b>Field Probe – 30 cm<sup>2</sup> Area-turns.</b> Refer to Paragraph 7.2.2 and see Figure 7-2.
<b>MAN-480</b>	<b>Model 480 Fluxmeter User's Manual.</b>

## Accessories (Continued)

Model No.	Description
<b>MRA-XXX</b> <b>MRT-XXX</b>	<p><b>Reference Magnets.</b> High-quality reference magnets are available in transverse (flat) and axial (round) configurations. Refer to Paragraph 7.4 and see Figure 7-6.</p> <p><b>MRA-312-100</b> Axial Reference Magnet: 0.312 inch inside diameter, 100 G, 1%</p> <p><b>MRA-312-200</b> Axial Reference Magnet: 0.312 inch inside diameter, 200 G, 1%</p> <p><b>MRA-312-300</b> Axial Reference Magnet: 0.312 inch inside diameter, 300 G, 1%</p> <p><b>MRA-312-500</b> Axial Reference Magnet: 0.312 inch inside diameter, 500 G, 1%</p> <p><b>MRA-312-1K</b> Axial Reference Magnet: 0.312 inch inside diameter, 1 kG, 1%</p> <p><b>MRA-312-2K</b> Axial Reference Magnet: 0.312 inch inside diameter, 2 kG, 1%</p> <p><b>MRT-062-200</b> Transverse Reference Magnet: 0.062 inch gap, 200 G, 1%</p> <p><b>MRT-062-500</b> Transverse Reference Magnet: 0.062 inch gap, 500 G, 1%</p> <p><b>MRT-062-1K</b> Transverse Reference Magnet: 0.062 inch gap, 1 kG, 0.5%</p> <p><b>MRT-062-2K</b> Transverse Reference Magnet: 0.062 inch gap, 2 kG, 0.5%</p> <p><b>MRT-062-5K</b> Transverse Reference Magnet: 0.062 inch gap, 5 kG, 0.5%</p> <p><b>MRT-062-10K</b> Transverse Reference Magnet: 0.062 inch gap, 10 kG, 5%</p> <p><b>MRT-343-50</b> Transverse Reference Magnet: 0.343 inch gap, 50 G, 1%</p> <p><b>MRT-343-100</b> Transverse Reference Magnet: 0.343 inch gap, 100 G, 1%</p>
<b>RM-1/2</b>	<p><b>Half-Rack Mounting Kit for One Model 480 Fluxmeter.</b> Half-length mounting panel and mounting ears to attach one Model 480 Fluxmeter to a 483 mm (19-inch) rack mount space. See Figure 7-7.</p>
<b>RM-2</b>	<p><b>Dual Mounting Shelf for Two Model 480 Fluxmeters.</b> Mounting panel and mounting ears to attach two Model 480 Fluxmeters to a 483 mm (19-inch) rack mount space. See Figure 7-8.</p>

## 7.2 FIELD MEASURING PROBES

Lake Shore offers two standard field measuring probes. Check Lake Shore brochures or our website for recent additions to this line.

Probes are accurately calibrated using field standards maintained at Lake Shore. Most standards are traceable to physical standards such as carefully controlled dimensions, or sometimes, proton resonance. Probes are calibrated for use in flux or flux density units. Pertinent calibration information including number of turns, effective area, and resistance are stored in a PROM located in the probe connector. Users need only attach the probe to the fluxmeter, turn on the instrument, set the range, and re-set the zero before taking readings. No manual input of coil parameters is necessary.

### 7.2.1 100 cm<sup>2</sup> Field Probe

For years, the most common field probe had 100 cm<sup>2</sup> area-turns. Specifications are defined as follows. See Figure 7-1.

Area-Turns (approx.)	100 cm <sup>2</sup>	
Coil Resistance (approx.)	6.5 Ω	
Average Coil Diameter	1.04 cm	
Frequency Range	10 kHz	
Operating Temp. Range	10 to 40 °C	
Input Resistance	10 kΩ	100 kΩ
DC Ranges	30 mVs (3 tesla) 3 mVs (300 mT)	300 mVs (30 tesla) 30 mVs (3 tesla)

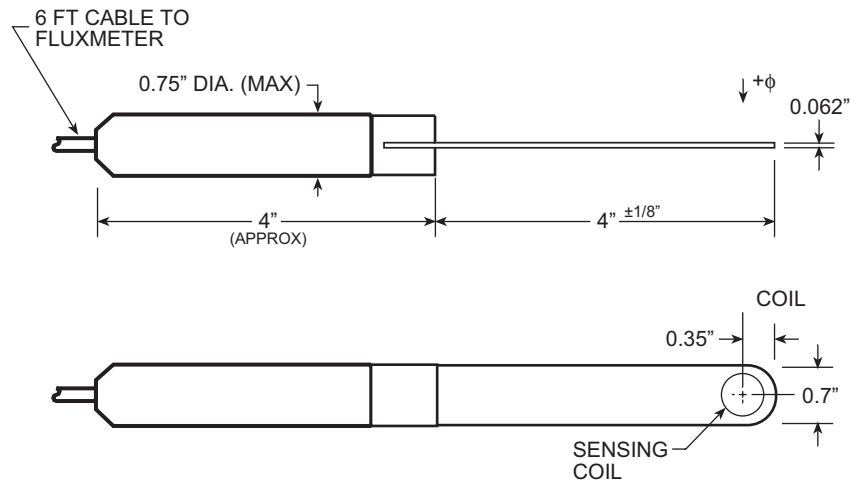

**NOTE:** +φ IS DESIGNATED AS THAT FLUX PASSING THROUGH THE COIL, INTO THE SIDE WITH THE LAKE SHORE LOGO ON THE PROBE HANDLE.

F-480-7-1.eps

**Figure 7-1. 100 cm<sup>2</sup> Field Probe**

### 7.2.2 30 cm<sup>2</sup> Field Probe

For measurements in narrow gaps or where field gradients dictate the use of a smaller coil diameter, Lake Shore offers the 30cm<sup>2</sup> field probe. Specifications are defined in as follows. See Figure 7-2.

Area-Turns (approx.)	30 cm <sup>2</sup>
Coil Resistance (approx.)	110 Ω
Average Coil Diameter	0.39 cm
Frequency Range	10 kHz
Operating Temp. Range	10 to 40 °C
Input Resistance (suggested)	100 kΩ
DC Ranges	300mVs (100 T) 30mVs (10 T)

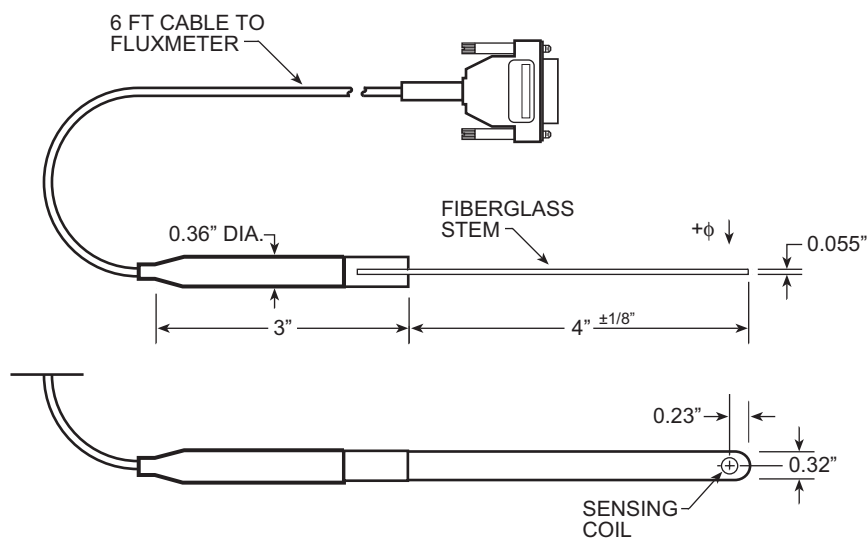

**NOTE:** +φ IS DESIGNATED AS THAT FLUX PASSING THROUGH THE COIL, INTO THE SIDE WITH THE LAKE SHORE LOGO ON THE PROBE HANDLE.

**Figure 7-2. 30 cm<sup>2</sup> Field Probe**

F-480-7-2.eps

### 7.3 HELMHOLTZ COILS

Lake Shore offers three Helmholtz coils: 2.5-, 6-, and 12-inch diameter. Check the latest Lake Shore brochures or our website for any recent additions to this line. These coils are accurately calibrated using field standards maintained at Lake Shore. Most standards are traceable to physical standards such as a coil of carefully controlled dimensions, or in some cases, to proton resonance. The coil constants are measured on the basis of the field generated by a current through the coil.

Users may connect to the Model 480 Fluxmeter with their own cable or a special Lake Shore cable. A user-supplied cable connects directly to the banana plugs on the Helmholtz and the back of the instrument, and the user must manually input the necessary coil parameters (listed on the label) into the fluxmeter using the **Coil Setup** key.

Lake Shore supplies a special cable with all factory-calibrated Helmholtz coils. This cable attaches between the coil banana terminals and the D-connector on the rear panel of the Model 480. Helmholtz coils are calibrated for use in Wb·cm units. Pertinent calibration information including the calibration constant and resistance are stored in Programmable Read-Only Memory (PROM) located in the cable connector. Users need only attach the coil to the Model 480 Fluxmeter, turn on the instrument, set the range, and reset the zero before taking readings. No manual input of coil parameters is necessary.

**CAUTION:** Each cable is usable only with a specific coil.

When users supply the connecting cable, the input resistance listed is only suggested. However, when a Lake Shore cable containing the pre-programmed PROM is used, the input channel indicated is the preferred channel for that coil and that channel will automatically be selected when the PROM data is loaded.

Model Number	FH-2.5		FH-6		FH-12	
Inside Diameter	2.5 inches		6 inches		12 inches	
Coil Resistance (Approx.)	35 Ω		110 Ω		140 Ω	
Operating Temp. Range	10 to 40 °C					
Coil Constant	0.013 Wb·cm/V·s		0.016 Wb·cm/V·s		0.047 Wb·cm/V·s	
Input Resistance	10 kΩ	100 kΩ	10 kΩ	100 kΩ	10 kΩ	100 kΩ
Ranges (Approx)	390 μWb·cm	3.9 mWb·cm	480 μWb·cm	4.8 mWb·cm	1.4 mWb·cm	14 mWb·cm
	39 μWb·cm	390 μWb·cm	48 μWb·cm	480 μWb·cm	140 μWb·cm	1.4 mWb·cm

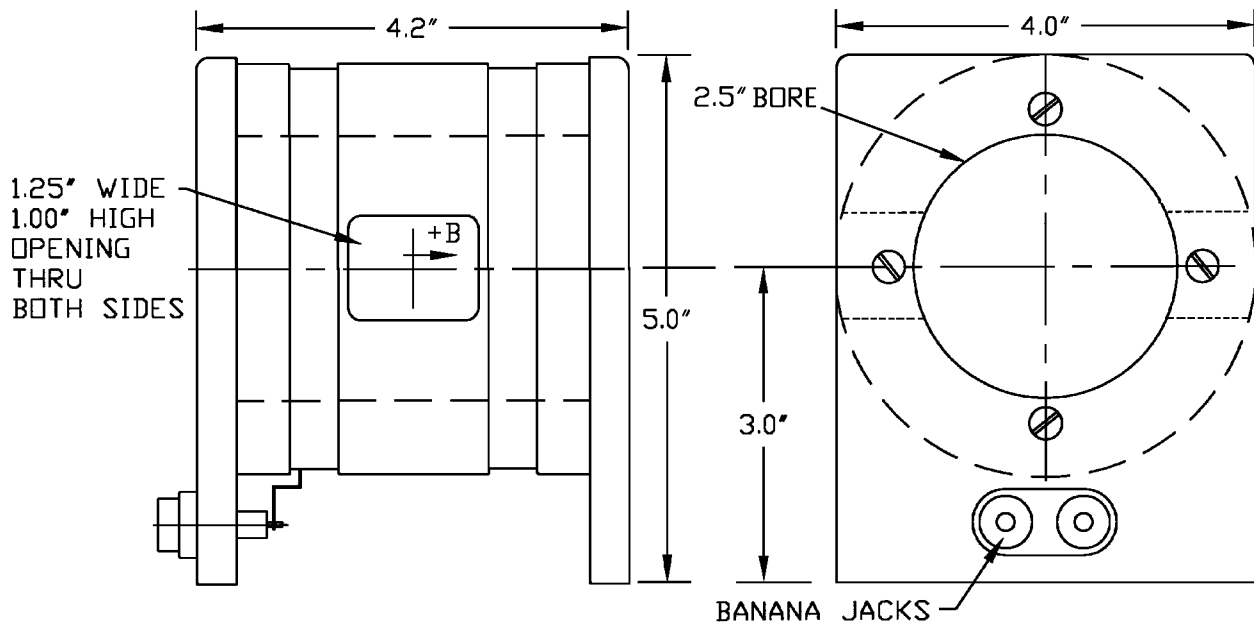
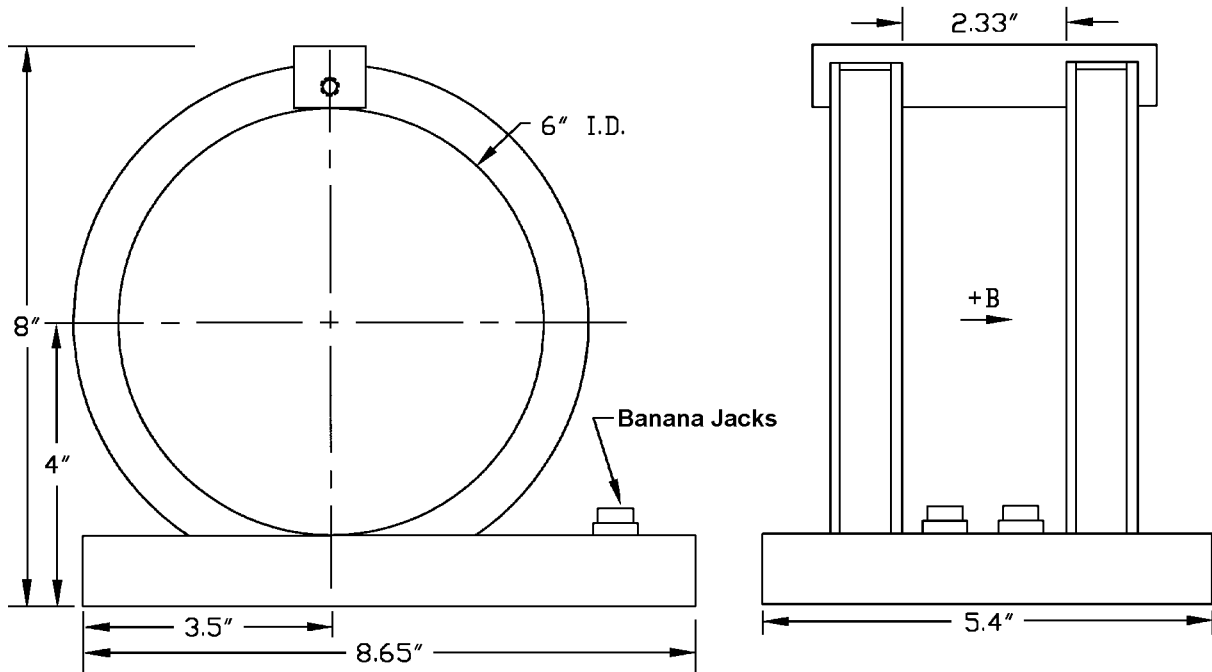

Figure 7-3. Model FH-2.5 Helmholtz Coil

P-480-7-3.bmp



P-480-7-4.bmp

Figure 7-4. Model FH-6 Helmholtz Coil

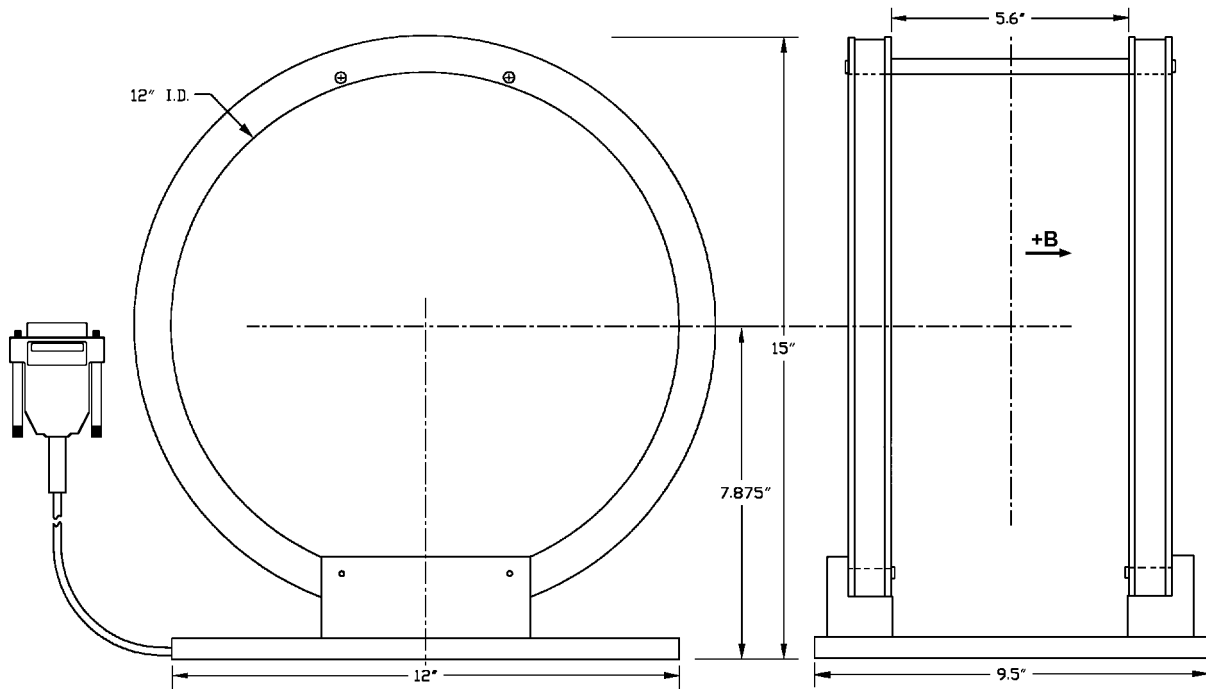

P-480-7-5.bmp

Figure 7-5. Model FH-12 Helmholtz Coil

## 7.4 REFERENCE MAGNETS

Magnetic reference standards containing highly stable permanent magnets have been in use for many years. The highest quality units are usually shielded from external magnetic effects and use Alnico V or VI magnets for long-term stability. They are supplied in both transverse (flat) and axial configurations.

Typical flat reference magnets are usually stabilized for use at ambient temperatures between 0 – 50 °C and have nominal temperature coefficients of about  $-0.02\%/^{\circ}\text{C}$ . Because the temperature coefficient is negative, the field strength will be reduced as the temperature rises. Since these references are temperature cycled during manufacture, their change with temperature is predictable and retraceable; they will always return to a known value at any specific ambient temperature.

The high-permeability shell which surrounds the reference magnet serves two function: (1) it shields the magnet from external field, and (2) serves as the flux return path. Physical damage to the outer shell can cause a permanent change in the gap flux density. Reference magnets should not be dropped or physically abused. Magnets of this type can have magnetic reference values ranging from 100 G to 20 kG, but the most widely-used value is 1 kG. Reference magnets accuracy is typically  $\pm 0.5\%$ , except for magnets of 200 G or less; for these magnets, the limit of error is generally  $\pm 1\%$ . The reference magnet gap is nominally 0.060 inch but may range from 0.040 to 0.250 inch for special units. The usable "plateau" in the reference gap generally encompasses an area of about 0.5 square inches.

In reference magnets used for axial field probes, Alnico V or VI is the usual magnet material, charged to saturation and stabilized down to a particular value. The same temperature coefficients hold true as in the transverse probe and the same care in handling must be observed. This assembly uses concentric mu-metal shield cans to protect the magnet from the effects of external magnetic field. Axial reference magnets are available in values up to 1 kG, with 500 G being the most widely-used value.

When a probe is inserted completely through the access guide, three distinct magnetic peaks will be observed on the gaussmeter. One peak occurs as the probe enters the magnet, a second (and greater) peak is observed as the midpoint is reached, and a third (smaller) peak is read as the probe leaves the magnet. The calibration point is the largest reading in the midpoint area. Its amplitude will be approximately twice that of the readings that occur where the probe enters or leaves the magnet.

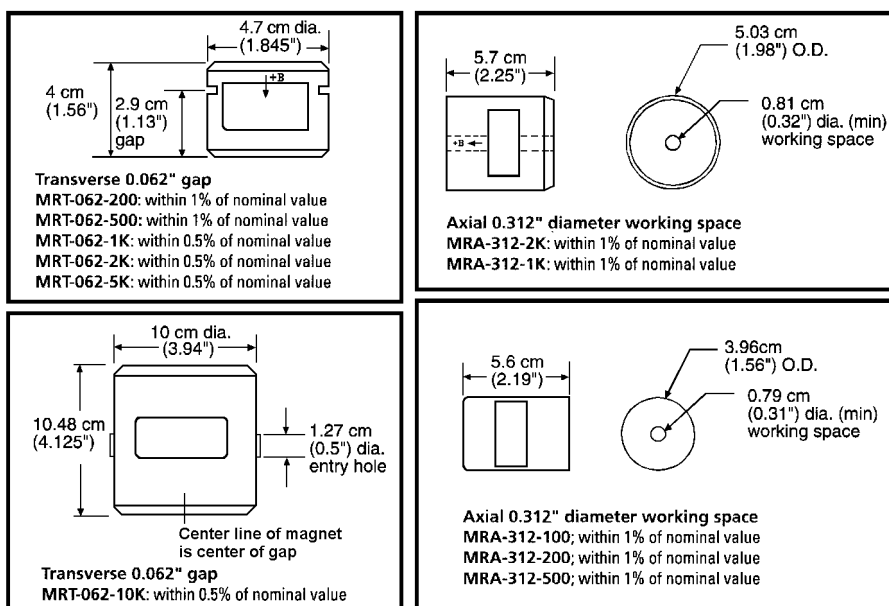

P-480-7-6.bmp

Figure 7-6. Lake Shore Reference Magnets

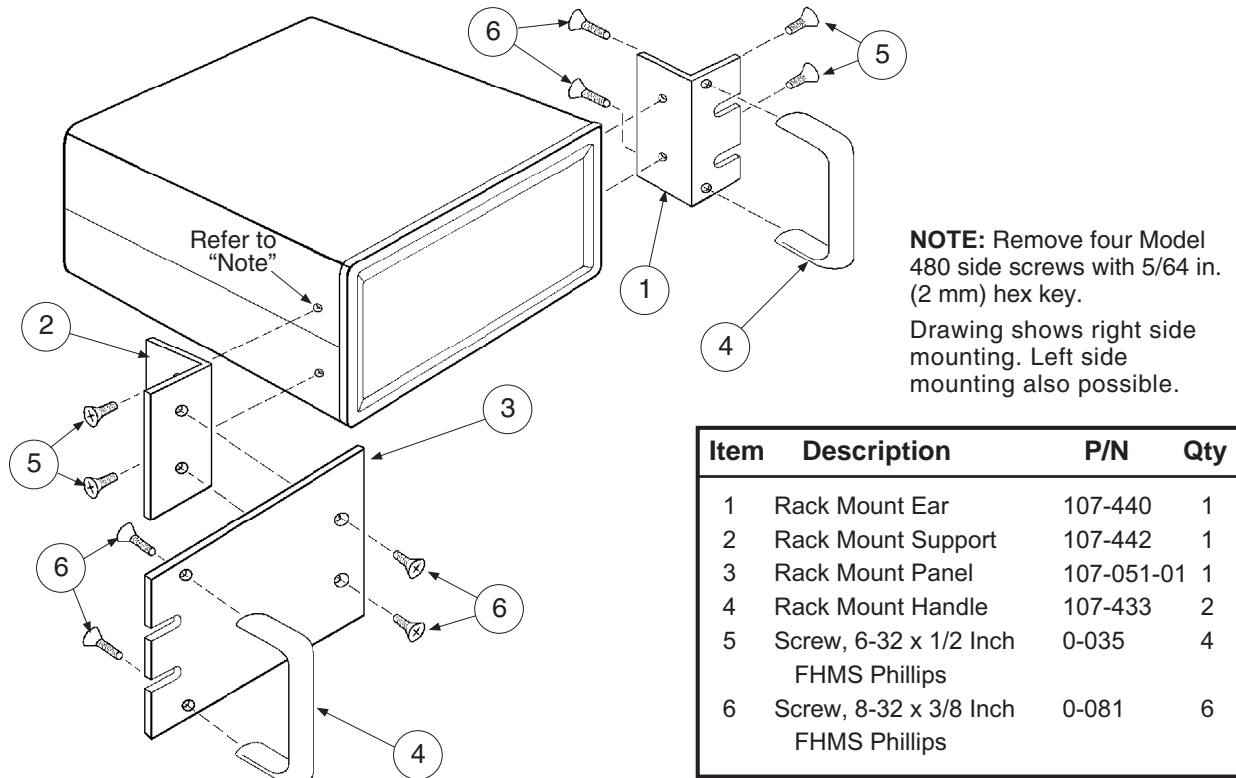

C-480-7-7.eps

**Figure 7-7. Model RM-1/2 Half-Rack Mounting Kit**

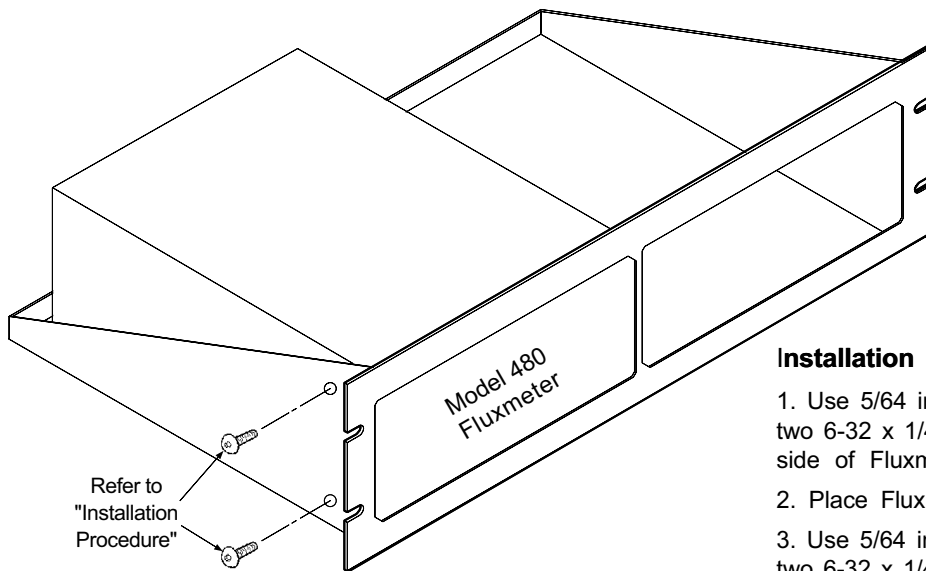

**Installation Procedure**

1. Use 5/64 inch (2 mm) hex key to remove two 6-32 x 1/4 black button head screws from side of Fluxmeter.
2. Place Fluxmeter on shelf.
3. Use 5/64 inch (2 mm) hex key to reinstall two 6-32 x 1/4 black button head screws through side of rack into corresponding holes in the side of the Fluxmeter.

C-480-7-8.eps

**Figure 7-8. Model RM-2 Dual Rack-Mount Shelf**

# CHAPTER 8

## SERVICE AND CALIBRATION

### 8.0 GENERAL

This chapter provides general service and calibration information for the Lake Shore Model 480 Fluxmeter. General maintenance precautions are described in Paragraph 8.1, electrostatic discharge in Paragraph 8.2, line voltage selection in Paragraph 8.3, fuse replacement in Paragraph 8.4, rear panel connector definitions in Paragraph 8.5, top of enclosure remove and replace procedure in Paragraph 8.6, EPROM replacement in Paragraph 8.7, error messages in Paragraph 8.8, and calibration in Paragraph 8.9.

There are no field serviceable parts inside the Model 480. Contact Lake Shore about specific problems with the Model 480.

### 8.1 GENERAL MAINTENANCE PRECAUTIONS

Below are general safety precautions unrelated to any other procedure in this publication. These are recommended precautions that personnel should understand and apply during the maintenance phase.

Keep away from live circuits. Installation personnel shall observe all safety regulations at all times. Turn off system power before making or breaking electrical connections. Regard any exposed connector, terminal board, or circuit board as a possible shock hazard. Discharge charged components only when such grounding results in no equipment damage. If a test connection to energized equipment is required, make the test equipment ground connection before probing the voltage or signal to be tested.

Do not install or service equipment alone. Do not reach into or adjust the equipment without having another person nearby capable of rendering aid.

If there is no power, verify the power cord is plugged into a live outlet and that both ends are securely plugged in. Next, check the fuse (see Paragraph 3.3.1.1).

Use this procedure to periodically clean the Model 480 to remove dust, grease, and other contaminants:

1. Clean front and back panels and case with soft cloth dampened with a mild detergent and water solution.

**NOTE:** Do *not* use aromatic hydrocarbons or chlorinated solvents to clean the Model 480. They may react with the plastic materials used in the controller or the silk screen printing on the back panel.

2. Clean the surface of printed circuit boards (PCBs) with clean, dry air at low pressure.

### 8.2 ELECTROSTATIC DISCHARGE

Electrostatic Discharge (ESD) may damage electronic parts, assemblies, and equipment. ESD is a transfer of electrostatic charge between bodies at different electrostatic potentials caused by direct contact or induced by an electrostatic field. The low-energy source that most commonly destroys Electrostatic Discharge Sensitive (ESDS) devices is the human body, which generates and retains static electricity. Simply walking across a carpet in low humidity may generate up to 35,000 volts of static electricity.

Current technology trends toward greater complexity, increased packaging density, and thinner dielectrics between active elements, which results in electronic devices with even more ESD sensitivity. Some electronic parts are more ESDS than others. ESD levels of only a few hundred volts may damage electronic components such as semiconductors, thick and thin film resistors, and piezoelectric crystals during testing, handling, repair, or assembly. Discharge voltages below 4000 volts cannot be seen, felt, or heard.

### 8.2.1 Identification of Electrostatic Discharge Sensitive Components

Below are various industry symbols used to label components as ESDS:



### 8.2.2 Handling Electrostatic Discharge Sensitive Components

Observe all precautions necessary to prevent damage to ESDS components before attempting installation. Bring the device and everything that contacts it to ground potential by providing a conductive surface and discharge paths. As a minimum, observe these precautions:

1. De-energize or disconnect all power and signal sources and loads used with unit.
2. Place unit on a grounded conductive work surface.
3. Ground technician through a conductive wrist strap (or other device) using 1 M $\Omega$  series resistor to protect operator.
4. Ground any tools, such as soldering equipment, that will contact unit. Contact with operator's hands provides a sufficient ground for tools that are otherwise electrically isolated.
5. Place ESDS devices and assemblies removed from a unit on a conductive work surface or in a conductive container. An operator inserting or removing a device or assembly from a container must maintain contact with a conductive portion of the container. Use only plastic bags approved for storage of ESD material.
6. Do not handle ESDS devices unnecessarily or remove from the packages until actually used or tested.

### 8.3 LINE VOLTAGE SELECTION

Use the following procedure to change the instrument line voltage selector. Verify the fuse value whenever line voltage is changed.

**WARNING: To avoid potentially lethal shocks, turn off controller and disconnect it from AC power before performing these procedures.**

1. Identify the line input assembly on the instrument rear panel. See Figure 8-1.
2. Turn the line power switch OFF (O).
3. Remove the instrument power cord.
4. With a small screwdriver, release the drawer holding the line voltage selector and fuse.
5. Slide out the removable plastic fuse holder from the drawer.
6. Rotate the fuse holder until the proper voltage indicator shows through the window.
7. Verify the proper fuse value.
8. Re-assemble the line input assembly in the reverse order.
9. Verify the voltage indicator in the window of the line input assembly.
10. Connect the instrument power cord.
11. Turn the line power switch On (I).

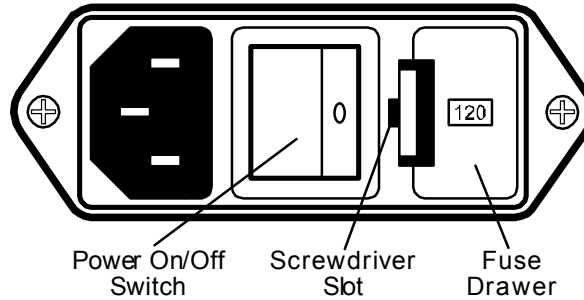

F-480-8-1.eps

**Figure 8-1. Power Fuse Access**

## 8.4 FUSE REPLACEMENT

Below is the procedure to remove and replace a line fuse. There are two basic power configurations: U.S. and International. Units produced for use in the U.S. have a single fuse on the hot. Units produced for International use have a double fuse for the hot and neutral. To change line input from the factory setting, use the appropriate fuse in the connector kit shipped with the instrument. Test fuse with ohmmeter. Do not rely on visual inspection of fuse.

**WARNING:** To avoid potentially lethal shocks, turn off controller and disconnect it from AC power before performing these procedures.

**CAUTION:** For continued protection against fire hazard, replace only with the same fuse type and rating specified for the line for the line voltage selected.

1. Locate line input assembly on the instrument rear panel. See Figure 8-1.
2. Turn power switch Off (O).
3. Remove instrument power cord.
4. With a small screwdriver, release the drawer holding the line voltage selector and fuse.
5. Remove existing fuse(s). Replace with proper Slow-Blow fuse ratings as follows:

100/120 V	0.25 A T 250 V	0.25 × 1.25 inches
220/240 V	0.200 A T 250 V	5 × 20 mm

6. Re-assemble line input assembly in reverse order.
7. Verify voltage indicator in the line input assembly window.
8. Connect instrument power cord.
9. Turn power switch On (I).

### 8.5 REAR PANEL CONNECTOR DEFINITIONS

The connectors on the rear panel of the Model 480 Fluxmeter are detailed in Figures 8-2 thru 8-6. Additional details for the IEEE-488 connector and various external serial cables are provided in Paragraphs 8.5.1 and 8.5.2 respectively.

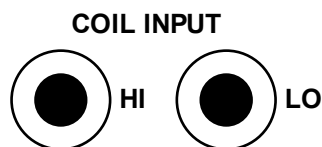

C-480-8-2.wmf

PIN	DESCRIPTION
HI	+Input = Red Banana Jack
LO	-Input = Black Banana Jack

Figure 8-2. COIL INPUT Connector Details

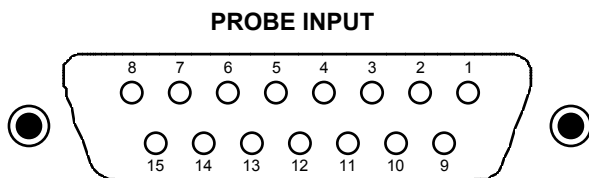

C-480-8-3.cvs

PIN	DESCRIPTION
1	Probe Coil Input Hi (Analog Signal)
2	No Connection
3	No Connection
4	No Connection
5	No Connection
6	No Connection
7	No Connection
8	No Connection
9	Probe Coil Input Lo (Analog Signal Ground)
10	No Connection
11	Digital Ground
12	+5 Volts (Power Output To Probe EEPROM)
13	EECLK (Output To Probe EEPROM)
14	EEDATA (Serial Input From Probe EEPROM)
15	No Connection

Figure 8-3. PROBE INPUT Connector Details

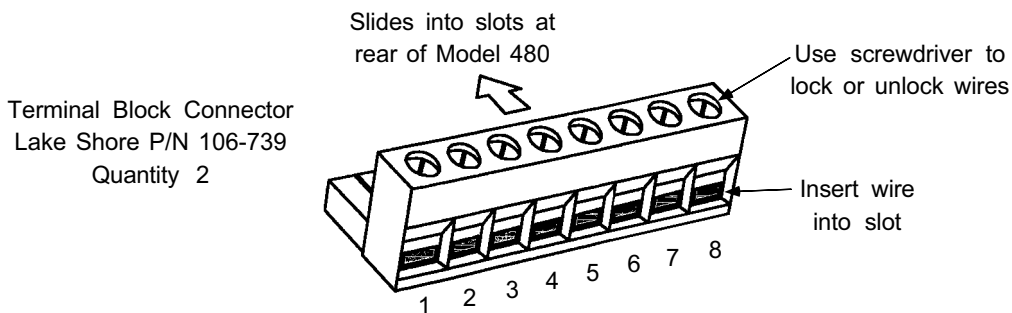

The terminal block plugged into the top slot has pin numbers 1-8, while the terminal block in the bottom slot has pin numbers 9-16.

C-480-8-4.eps

PIN	DESCRIPTION
1	High Alarm N.O.
2	High Alarm Common
3	High Alarm N.C.
4	Low Alarm N.O.
5	Low Alarm Common
6	Low Alarm N.C.
7	Monitor Output – Signal
8	Monitor Output – Ground
9	Middle Alarm N.O.
10	Middle Alarm Common
11	Middle Alarm N.C.
12	External Reset
13	Ground for Ext. Reset or Optional Input
14	Optional Input
15	Corrected Output – Signal
16	Corrected Output – Ground

Figure 8-4. Relays and Analog Signals Terminal Block

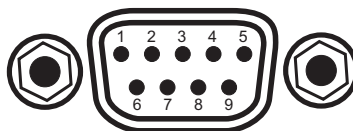

F-480-8-5.eps

Model 480 Fluxmeter		Computers and Printers			
DE-9P		DB-25P		DE-9P	
Pin	Description	Pin	Description	Pin	Description
1	No Connection	2	TD (out)	1	DCD (in)
2	Receive Data (RD in)	3	RD (in)	2	RD (in)
3	Transmit Data (TD out)	4	RTS (out)	3	TD (out)
4	Data Terminal Ready (DTR out)	5	CTS (in)	4	DTR (out)
5	Ground (GND)	6	DSR (in)	5	GND
6	Data Set Ready (DSR in)	7	GND	6	DSR (in)
7	Data Terminal Ready (DTR out) (tied to 4)	8	DCD (in)	7	RTS (out)
8	No Connection	20	DTR (out)	8	CTS (in)
9	No Connection	22	Ring in (in)	9	Ring in (in)

Figure 8-5. SERIAL I/O Connector Details

### 8.5.1 Serial Interface Cable Wiring

The following are suggested cable wiring diagrams for connecting the Model 480 Serial Interface to various Customer Personal Computers (PCs).

#### Model 480 to PC Serial Interface – PC with DE-9P

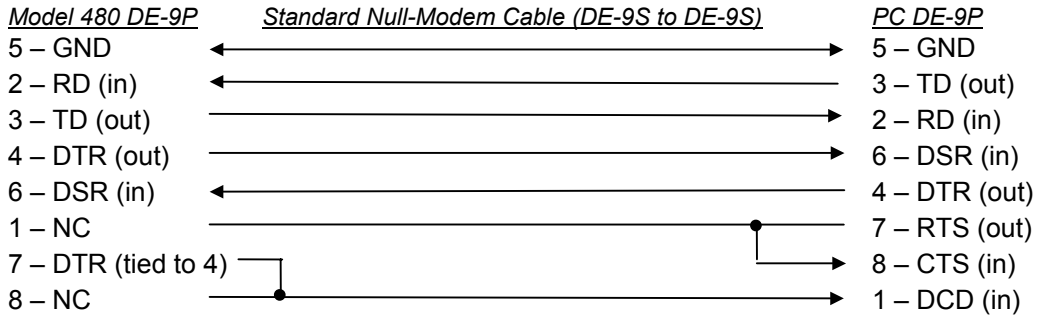

#### Model 480 to PC Serial Interface – PC with DB-25P

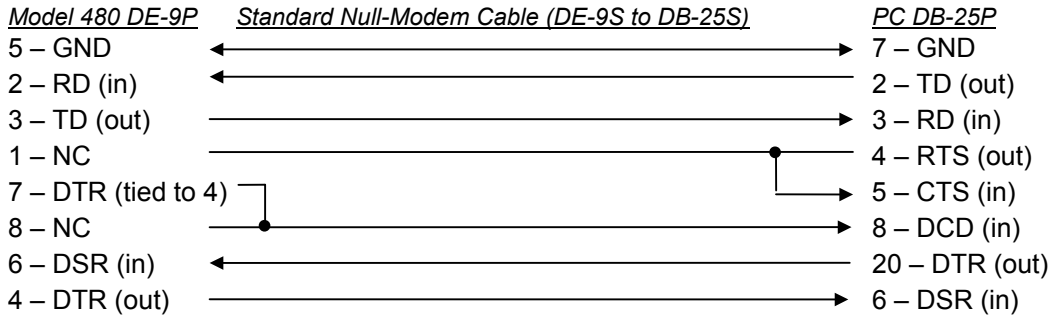

#### Model 480 to PC Interface using Null Modem Adapter

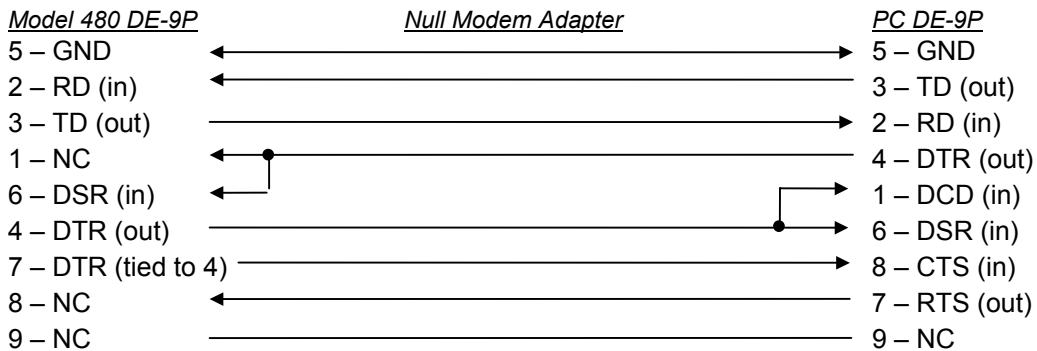

**NOTE:** Same as null modem cable design except PC CTS is provided from the Model 480 on DTR.

### 8.5.2 IEEE-488 Interface Connector

Connect to the IEEE-488 Interface connector on the Model 480 rear with cables specified in the IEEE-488-1978 standard document. The cable has 24 conductors with an outer shield. The connectors are 24-way Amphenol 57 Series (or equivalent) with piggyback receptacles to allow daisy-chaining in multiple device systems. The connectors are secured in the receptacles by two captive locking screws with metric threads.

The total length of cable allowed in a system is 2 meters for each device on the bus, or 20 meters maximum. A system may be composed of up to 15 devices. Figure 8-6 shows the IEEE-488 Interface connector pin location and signal names as viewed from the Model 480 rear panel.

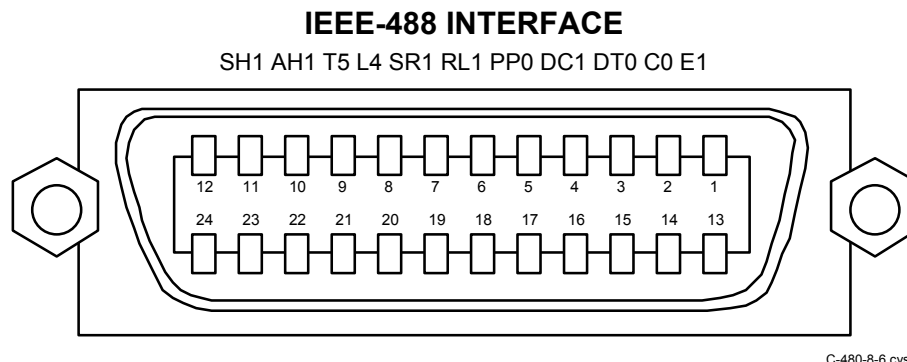

PIN	SYMBOL	DESCRIPTION
1	DIO1	Data Input/Output Line 1
2	DIO2	Data Input/Output Line 2
3	DIO3	Data Input/Output Line 3
4	DIO4	Data Input/Output Line 4
5	EOI	End Or Identify
6	DAV	Data Valid
7	NRFD	Not Ready For Data
8	NDAC	Not Data Accepted
9	IFC	Interface Clear
10	SRQ	Service Request
11	ATN	Attention
12	SHIELD	Cable Shield
13	DIO5	Data Input/Output Line 5
14	DIO6	Data Input/Output Line 6
15	DIO7	Data Input/Output Line 7
16	DIO8	Data Input/Output Line 8
17	REN	Remote Enable
18	GND 6	Ground Wire – Twisted pair with DAV
19	GND 7	Ground Wire – Twisted pair with NRFD
20	GND 8	Ground Wire – Twisted pair with NDAC
21	GND 9	Ground Wire – Twisted pair with IFC
22	GND 10	Ground Wire – Twisted pair with SRQ
23	GND11	Ground Wire – Twisted pair with ATN
24	GND	Logic Ground

**Figure 8-6. IEEE-488 Rear Panel Connector Details**

## 8.6 TOP OF ENCLOSURE REMOVAL AND REPLACEMENT

**WARNING:** To avoid potentially lethal shocks, turn off controller and disconnect it from AC power line before performing this procedure. Only qualified personnel should perform this procedure.

### 8.6.1 Removal Procedure

1. Set power switch to Off (O) and disconnect power cord from rear of unit.
2. If attached, remove 19-inch rack mounting brackets.
3. Use 5/64 hex key to remove four screws attaching top panel to unit.
4. Use 5/64 hex key to loosen four screws attaching bottom panel to unit.
5. Carefully remove the back bezel by sliding it straight back away from the unit.
6. Slide the top panel back and remove it from the unit.

### 8.6.2 Installation Procedure

1. Slide the top panel forward in the track provided on each side of the unit.
2. Carefully replace the back bezel by sliding it straight into the unit.
3. Use 5/64 hex key to install four screws attaching top panel to unit.
4. Use 5/64 hex key to tighten four screws attaching bottom panel to unit.
5. If required, reattach 19-inch rack mounting brackets.
6. Connect power cord to rear of unit and set power switch to On (I).

## 8.7 EPROM REPLACEMENT

The operating software for the Model 480 is contained on one Erasable Programmable Read Only Memory (EPROM) Integrated Circuit (IC). The reference designator for the EPROM is U53. The EPROM has a sticker on top labeled with "M480.HEX" and the date. Use the following procedure to replace the EPROM.

**CAUTION:** The EPROM is an Electrostatic Discharge Sensitive (ESDS) device. Wear shock-proof wrist straps (with a resistor that limits current to <5 mA) to prevent injury to service personnel and to avoid inducing an Electrostatic Discharge (ESD) into the device. Refer to Paragraph 8.2.

1. Follow the top of enclosure REMOVAL procedure in Paragraph 8.6.1.
2. Remove four Phillips-head screws attaching transformer bracket to the Model 480 chassis. Carefully pull transformer bracket up and sufficiently out of the way to gain access to the Operating Software EPROM. See Figure 8-7.
3. Locate EPROM U53 (M480.HEX) on the main circuit board. Note orientation of existing IC.

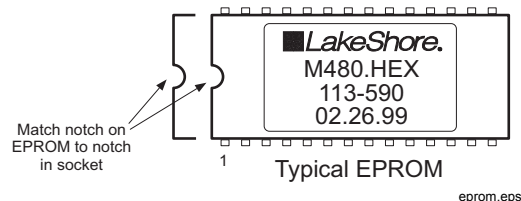

4. Use IC puller to remove existing EPROM from socket.
5. Noting orientation of new EPROM, use an IC insertion tool to place new device into socket.
6. Install four Phillips-head screws attaching transformer bracket to the Model 480 chassis.
7. Follow the top of enclosure INSTALLATION procedure in Paragraph 8.6.2.

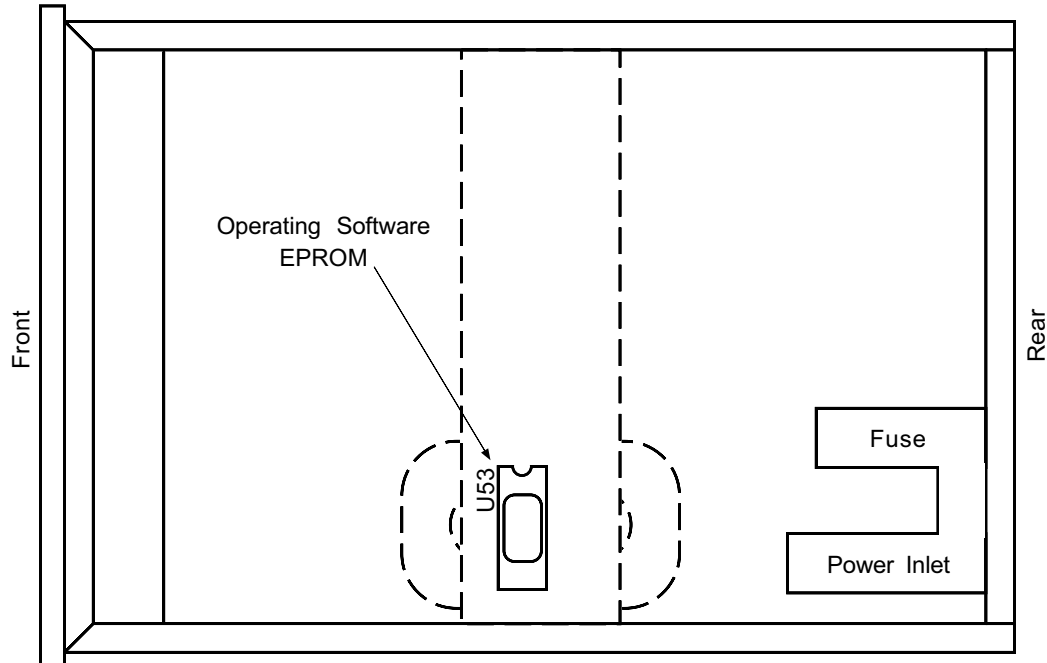

C-480-8-7.eps

**Figure 8-7. Location of Operation Software EPROM**

## 8.8 ERROR MESSAGES

The following is a list of Model 480 error messages that may be seen during normal operation.

- |  |   |
|--|---|
| <b>NOVRAM Defective</b>                | Cannot write to the NOVRAM. NOVRAM is physically malfunctioning. Return instrument to Lake Shore for repair and recalibration.  |
| <b>NOVRAM Corrupt</b>                  | Information in the NOVRAM is not recognized. Cycle the power to see if the error message disappears. If that does not resolve the problem, press the <b>Escape</b> and <b>Enter</b> keys to initialize the NOVRAM. This will permit continued operation but the calibration data will be deleted. Return instrument to Lake Shore for repair and recalibration. |
| <b>Invalid Calibration</b>             | Press the <b>Escape</b> and <b>Enter</b> keys simultaneously. The instrument is out of calibration but can still be used. Reading values can be as much as 5% off. Return the instrument to Lake Shore for recalibration.   |
| <b>Drift Adjust Failed</b>             | The Auto Adjust feature was not able to compensate for the drift of the instrument. Make sure the coil is properly connected to the instrument and the coil is not in a changing magnetic field.  |
| <b>Invalid Probe</b>                   | Data could not be read from or written to the probe. Either no probe is attached to the instrument or the probe attached is not compatible with the Model 480 Fluxmeter.  |
| <b>Can Not Modify Lake Shore Probe</b> | A Lake Shore calibrated probe is attached to the instrument. Coil parameters cannot be modified and data cannot be written to the probe.  |
| <b>* LOCKED *</b>                      | Keypad is locked. Refer to Paragraph 5.14 to unlock the keypad.   |

## 8.9 CALIBRATION PROCEDURE

The first step of Model 480 calibration is to reset all the calibration parameters to nominal starting points. This step is done for all ranges at one time by one command. The second step obtains a Model 480 reading on a given range. Third is the calculation of a corrective calibration constant for that given range from the Model 480 actual reading and an ideal reading derived from a digital voltmeter reading at the input of the Model 480. Forth, stores the calibration constant in the proper location for the given range. The process repeats through all ranges of the Model 480. Monitor and Corrected Analog outputs are done in a similar fashion. The operation of the Model 480 is handled manually from the front panel but the actual placing of derived calibration data in appropriate memory locations is handled solely by the computer interface. Although this procedure describes field calibration of the Model 480, it is highly recommended that the unit be returned to Lake Shore for periodic calibration.

### 8.9.1 Required Equipment List

1. Computer with communication interface established with Model 480. Can be accomplished by either RS-232 or IEEE-488 Interface and cable.
2. Digital Voltmeter: Basic DC accuracy 0.01%, AC accuracy 0.5% (5 Hz. to 50 kHz, sine wave), Suggested: Hewlett-Packard Model HP34401A.
3. Oscillator: 0.1 Hz. to 50 kHz, sine, burst mode square wave, amplitude accuracy  $\pm 2\%$ , frequency accuracy 0.01%, output impedance 50  $\Omega$ . Suggested: Hewlett-Packard HP33120.
4. 1  $\mu\text{F}$ , 50 V, non-polar, (mylar or polypropylene) capacitor to be connected in series with the oscillator signal lead during AC calibration. The actual accuracy of the capacitor is not a major issue since the digital voltmeter is used to actually measure the voltage at the Model 480 terminals. (Used in AC calibrations.)
5. 100:1 Resistive Attenuator (series 10.1 k $\Omega$  resistor with shunt 102  $\Omega$  resistor suggested), to be connected between the oscillator output and Model 480 input. The actual accuracies of the resistors are not a major issue since the digital voltmeter is used to actually measure the voltage at the Model 480 terminals. (Used in DC calibrations.)

### 8.9.2 A/D Reference Voltages

**NOTE:** The adjustment of the following voltage trimpots voids any existing calibration data of the instrument and requires completion of the entire calibration procedure.

1. Set the Model 480 to AC, non-peak operation, 30 mV·s range, 100 k $\Omega$  input resistance, no input signal.
2. Measure the +2.5 VDC at pin U27-12 referenced to signal ground test point TP5 and adjust R69 for 2.5 VDC  $\pm 10 \mu\text{V}$ .
3. Measure the -2.5 VDC test point TP13 referenced to signal ground test point TP5 and adjust R81 for -2.5 VDC  $\pm 10 \mu\text{V}$ .

### 8.9.3 Initialize for Calibration

**NOTE:** This step replaces all, existing calibration data with nominal, starting values.

1. Send "CALCLR" command to the Model 480 via the computer interface.

### 8.9.4 AC Peak Offset

1. Short the input terminals of the Model 480.
2. Set Model 480 to AC, Dual Peak operation, 100 kΩ Input Resistance, 30 mV·s range.
3. Set Model 480 units to Volts (available only through computer interface, send "UNITS 0" over the computer interface).
4. Reset and read offsets directly as voltages on the Model 480.
5. Take 10 readings.
6. Average all positive readings, average all negative readings.
7. Send positive average reading to Range Voltage Offset locations 8, 9, 10, 11, 26, 27, 28, 29 from the computer using the form "CALZERO <location #> <reading>"
8. Send negative average reading to Range Voltage Offset locations 14, 15, 16, 17, 32, 33, 34, 35 from the computer using the form "CALZERO <location #> <reading>" (Include the "-" with the reading.)

### 8.9.5 AC RMS and AC Peak Gain Calibration

The following procedure is to be repeated for each range entry in Table 8-1.

**Table 8-1. AC Calibration Table**

Range	Input R	Freq	Amplitude	Vs(nom)	CalRng#	Vs(pk)	Pk+Rng#	Pk-Rng#
30 mV·s	100 kΩ	60 Hz.	5.655 Vrms	15 mV·s	20	21.2 mV·s	26	32
3 mV·s	100 kΩ	60 Hz.	0.7540 Vrms	2 mV·s	21	2.83 mV·s	27	33
300 μV·s	100 kΩ	1 kHz.	1.257 Vrms	200 μV·s	22	283 μV·s	28	34
30 μV·s	100 kΩ	1 kHz.	0.1257 Vrms	20 μV·s	23	n/a	n/a	n/a
3 mV·s	10 kΩ	60 Hz.	0.7540 Vrms	2 mV·s	2	2.83 mV·s	8	14
300 μV·s	10 kΩ	1 kHz.	1.257 Vrms	200 μV·s	3	283 μV·s	9	15
30 μV·s	10 kΩ	1 kHz.	0.1257 Vrms	20 μV·s	4	28.3 μV·s	10	16
3 μV·s	10 kΩ	10 kHz.	0.1257 Vrms	2 μV·s	5	n/a	n/a	n/a

#### **AC RMS Calibration**

1. Connect Oscillator to Model 480 input terminals (observe ground) using the 1 μF series capacitor in series with the signal lead.
2. Connect DVM in parallel with the Model 480 input terminals, set to AC.
3. Set Model 480 units to mV·s.
4. Set Model 480 to AC, non-peak operation.
5. Set Model 480 range (per Table 8-1).
6. Set Model 480 input resistance (per Table 8-1).
7. Set Oscillator to the testing amplitude and frequency (per Table 8-1), sine, continuous.
8. Calculate Ideal V·s = Voltmeter reading /  $2\pi f$ .
9. Wait 30 seconds.
10. Get Actual Model 480 reading.
11. Calculate Calibration Constant =  $1e-7 \times \text{Ideal} / \text{Actual}$ .

**NOTE:** This value must be  $1e-7 \pm 11\%$ . A value outside this tolerance indicates a major malfunction of the Model 480 that requires repair.

**AC RMS and AC Peak Gain Calibration (Continued)**

- Send Calibration Constant to the appropriate range location (per Table 8-1) from the computer using the form "CALGAIN <location#> <x.xxxxxe-x>".

**AC Peak Calibration**

- Set Model 480 to Dual Peak operation.
  - Calculate Ideal (peak) = Ideal V·s (from Step 8 above)  $\times$  1.4142.
  - Wait 30 seconds.
  - Reset the Model 480.
  - Get Actual (peak) readings. Average 10 readings each taken 1 second after a reset.
  - Calculate Calibration Constant =  $1e-7 \times$  Ideal (peak) / Actual (averaged).
- NOTE:** This value must be  $1e-7 \pm 11\%$ . A value outside this tolerance indicates a major malfunction of the Model 480 that requires repair.
- Send the Calibration Constant to the appropriate, positive peak, range location (per Table 8-1) from the computer using the form "CALGAIN <location#> <x.xxxxxe-x>".
  - Send the same Calibration Constant to the appropriate, negative peak, range location (per Table 8-1) from the computer using the form "CALGAIN <location#> <x.xxxxxe-x>".
  - Repeat Steps 4 thru 21 for next range of Table 8-1 until all AC ranges are calibrated.

**8.9.6 DC and DC Peak Calibration**

The following procedure is to be repeated for each range entry in Table 8-2.

**Table 8-2. DC Calibration Table**

Range	Input R	Freq.	Period	Amplitude	Offset	Vs(nom)	Cal Rng#	Pk+Rng#	Pk-Rng#
300 mV·s	100 k $\Omega$	0.1 Hz.	5 sec	5 volts p-p	2.5 volts	250 mV·s	18	24	30
30 mV·s	100 k $\Omega$	1 Hz.	0.5 sec	5 volts p-p	2.5 volts	25 mV·s	19	25	31
30 mV·s	10 k $\Omega$	1 Hz.	0.5 sec	5 volts p-p	2.5 volts	25 mV·s	0	6	12
3 mV·s	10 k $\Omega$	10 Hz.	0.05 sec	5 volts p-p	2.5 volts	2.5 mV·s	1	7	13

**DC Calibration**

- Install 100:1 resistive attenuator between oscillator and Model 480 input terminals.
- Connect DVM in parallel with the Model 480 input terminals, set to DC.
- Set Model 480 units to V·s.
- Set Model 480 to DC, non-peak operation.
- Set Model 480 range (per Table 8-2).
- Set Model 480 input resistance (per Table 8-2).
- Set Oscillator to the testing amplitude, offset and frequency (per Table 8-2), square wave, burst mode.

**NOTE:** Table 8-2 amplitudes are at the oscillator output. DVM measured levels will be attenuated by 100:1.

- Measure the DC voltage to the Model 480 input and adjust the oscillator offset to make it as near 0 volts as possible.
- Set Model 480 for drift Auto Adjust and wait 30 seconds for the routine to complete.
- Verify an acceptable drift hold less than  $\pm 2$   $\mu$ Vs.
- Trigger one oscillator burst, measure DC voltage to the Model 480 during the burst.

**DC and DC Peak Calibration (Continued)**

12. Get actual Model 480 reading within 1 second of burst end.
13. Calculate Ideal V·s = Burst period × DC voltage to Model 480.
14. Calculate the Calibration Constant =  $1e-6 \times \text{Ideal V·s} / \text{Actual V·s}$ .

**NOTE:** This value must be  $1e-6, \pm 5\%$ . A value outside this tolerance indicates a major malfunction of the Model 480 that requires repair.

15. Send Calibration Constant to the appropriate range location (per Table 8-2) from the computer using the form "CALGAIN <location#> <x.xxxxxe-x>".

**DC Peak Calibration**

16. Set Model 480 to Dual Peak operation.
17. Reset Model 480, wait 30 seconds, reset Model 480 again.
18. Trigger one oscillator burst, measure DC voltage to Model 480 during the burst.
19. Calculate Ideal V·s = Burst period × DC voltage to Model 480.
20. Get actual Model 480 positive peak reading.
21. Calculate the Calibration Constant =  $1e-6 \times \text{Ideal V·s} / \text{Actual V·s}$ .

**NOTE:** This value must be  $1e-6 \pm 5\%$ . A value outside this tolerance indicates a major malfunction of the Model 480 that requires repair.

22. Send Calibration Constant to the appropriate positive peak range location (per Table 8-2) from the computer using the form "CALGAIN <location#> <x.xxxxxe-x>".
23. Send the same Calibration Constant to the appropriate negative peak range location (per Table 8-2) from the computer using the form "CALGAIN <location#> <x.xxxxxe-x>".
24. Repeat Steps 5 thru 24 for each range of Table 8-2 until all DC ranges are calibrated.

**8.9.7 Output Calibration**

The Model 480 output calibration consists of monitor and corrected output calibrations detailed in Paragraphs 8.9.7.1 and 8.9.7.2.

**8.9.7.1 Monitor Output Calibration**

1. Connect Oscillator to Model 480 input terminals (observe ground) using the 1  $\mu\text{F}$  series capacitor in series with the signal lead.
2. Connect DVM to Model 480 Monitor Output, set to AC.
3. Set Model 480 to AC, 100 k $\Omega$  input resistance, 30 mV·s range, non-peak operation.
4. Set oscillator to 5.655 Vrms, 60 Hz, sine, continuous.
5. Calculate Ideal Monitor Vrms = Model 480 reading × 100/s (nominal = 1.5 Vrms).
6. Calculate Monitor Gain Constant = Ideal Monitor Vrms / Actual Monitor Vrms.
7. Send Monitor Gain Constant to appropriate location using the "CALDAC <.xxxxxx>" command.

**Note:** This value must be between 0.8 and 1.0. A value outside this range indicates a major malfunction of the Model 480 that requires repair.

### 8.9.7.2 Corrected Output Calibration

1. Connect DVM to Model 480 Corrected Output, set to DC.
2. Set Model 480 Analog output to manual, -100%.
3. Corrected Offset Constant =  $-(\text{Voltmeter reading 1} + 10.000 \text{ Vdc}) / 20$ .
4. Set Model 480 Analog output to manual, +100%.
5. Corrected DAC Gain Constant =  $20 / ((\text{Voltmeter reading 2}) - (\text{Voltmeter reading 1}))$ .
6. Send Corrected DAC Offset Constant using the form "CALCOFF .xxxxxx".

**NOTE:** This value must be between -0.005 and 0. A value outside this range indicates a major malfunction of the Model 480 that requires repair.

7. Send Corrected DAC Gain Constant using the form "CALCGAIN <.xxxxxx>".

**NOTE:** This value must be between 0.95 and 1.0. A value outside this range indicates a major malfunction of the Model 480 that requires repair.

### 8.9.8 Finalize Calibration

1. Finalize calibration by sending "POKEM F207,31" over the computer interface.
2. Set the unit serial number using the form "SNUM xxxxxx", sent over the interface.
3. The calibration is now complete.

# APPENDIX A

## GLOSSARY OF TERMINOLOGY

**accuracy.** The degree of correctness with which a measured value agrees with the true value.<sup>2</sup>

**electronic accuracy.** The accuracy of an instrument independent of the sensor.

**sensor accuracy.** The accuracy of a temperature sensor and its associated calibration or its ability to match a standard curve.

**algorithm.** A set of well-defined rules for the solution of a problem in a finite number of steps.<sup>1</sup>

**American Standard Code for Information Exchange (ASCII).** A standard code used in data transmission, in which 128 numerals, letters, symbols, and special control codes are represented by a 7-bit binary number as follows:

Bits		Col.																
		0	1	2	3	4	5	6	7									
b <sub>7</sub>	b <sub>6</sub>	b <sub>5</sub>	b <sub>4</sub>	b <sub>3</sub>	b <sub>2</sub>	b <sub>1</sub>	b <sub>0</sub>											
0	0	0	0	0	0	0	0	NUL	DLE	SP	0	'	P	@	p			
0	0	0	0	1	1	1	1	SOH	DC1	!	1	A	Q	a	q			
0	0	1	0	0	0	0	0	STX	DC2	"	2	B	R	b	r			
0	0	1	1	1	1	1	1	ETX	DC3	#	3	C	S	c	s			
0	1	0	0	0	0	0	0	EOT	DC4	\$	4	D	T	d	t			
0	1	0	1	1	1	1	1	ENG	NAK	%	5	E	U	e	u			
0	1	1	0	0	0	0	0	ACK	SYN	&	6	F	V	f	v			
0	1	1	1	1	1	1	1	BEL	ETB	'	7	G	W	g	w			
1	0	0	0	0	0	0	0	BS	CAN	(	8	H	X	h	x			
1	0	0	1	1	1	1	1	HT	EM	)	9	I	Y	i	y			
1	0	1	0	0	0	0	0	LF	SS	*	:	J	Z	j	z			
1	0	1	1	1	1	1	1	VT	ESC	+	;	K	[	k	(			
1	1	0	0	0	0	0	0	FF	FS	,	<	L	~	l	~			
1	1	0	1	1	1	1	1	CR	GS	-	=	M	]	m	)			
1	1	1	0	0	0	0	0	SO	RS	.	>	N	^	n	!			
1	1	1	1	1	1	1	1	SI	US	/	?	O	_	o	DEL			

**American Wire Gage (AWG).** Wiring sizes are defined as diameters in inches and millimeters as follows:

AWG	Dia. In.	Dia. mm	AWG	Dia. In.	Dia. mm	AWG	Dia. In.	Dia. mm	AWG	Dia. In.	Dia. mm
1	0.2893	7.348	11	0.0907	2.304	21	0.0285	0.7230	31	0.0089	0.2268
2	0.2576	6.544	12	0.0808	2.053	22	0.0253	0.6438	32	0.0080	0.2019
3	0.2294	5.827	13	0.0720	1.829	23	0.0226	0.5733	33	0.00708	0.178
4	0.2043	5.189	14	0.0641	1.628	24	0.0207	0.5106	34	0.00630	0.152
5	0.1819	4.621	15	0.0571	1.450	25	0.0179	0.4547	35	0.00561	0.138
6	0.1620	4.115	16	0.0508	1.291	26	0.0159	0.4049	36	0.00500	0.127
7	0.1443	3.665	17	0.0453	1.150	27	0.0142	0.3606	37	0.00445	0.1131
8	0.1285	3.264	18	0.0403	1.024	28	0.0126	0.3211	38	0.00397	0.1007
9	0.1144	2.906	19	0.0359	0.9116	29	0.0113	0.2859	39	0.00353	0.08969
10	0.1019	2.588	20	0.0338	0.8118	30	0.0100	0.2546	40	0.00314	0.07987

**ampere.** The constant current that, if maintained in two straight parallel conductors of infinite length, of negligible circular cross section, and placed one meter apart in a vacuum, would produce between these conductors a force equal to  $2 \times 10^{-7}$  newton per meter of length.<sup>2</sup> This is one of the base units of the SI.

**ampere-turn.** A MKS unit of magnetomotive force equal to the magnetomotive force around a path linking one turn of a conducting loop carrying a current of one ampere; or 1.26 gilberts.

**ampere/meter (A/m).** The SI unit for magnetic field strength (H). 1 ampere/meter =  $4\pi/1000$  oersted  $\approx$  0.01257 oersted.

**analog data.** Data represented in a continuous form, as contrasted with digital data having discrete values.<sup>1</sup>

**analog output.** A voltage output from an instrument that is proportional to its input. From an instrument such as a digital voltmeter, the output voltage is generated by a digital-to-analog converter with a discrete number of voltage levels.

**anode.** The terminal that is positive with respect to the other terminal when the diode is biased in the forward direction.<sup>2</sup>



**area.** A measure of the size of a two-dimensional surface, or of a region on such a surface.<sup>1</sup>

**area-turns.** A coil parameter produced by the multiplication of a magnet's area and number of turns. Gives an indication of the sensitivity of a coil. In the Model 480, the area turns of a coil must be entered to perform flux density measurements in units of gauss (G) or tesla (T).

**B.** Symbol for magnetic flux density. See Magnetic Flux Density.

**baud.** A unit of signaling speed equal to the number of discrete conditions or signal events per second, or the reciprocal of the time of the shortest signal element in a character.<sup>2</sup>

**bit.** A contraction of the term "binary digit"; a unit of information represented by either a zero or a one.<sup>2</sup>

**calibration.** To determine, by measurement or comparison with a standard, the correct (accurate) value of each scale reading on a meter or other device, or the correct value for each setting of a control knob.<sup>1</sup>

**cathode.** The terminal from which forward current flows to the external circuit.<sup>2</sup>



**Celsius (°C) Scale.** A temperature scale that registers the freezing point of water as 0 °C and the boiling point as 100 °C under normal atmospheric pressure. Celsius degrees are purely derived units, calculated from the Kelvin Thermodynamic Scale. Formerly known as “centigrade.” See Temperature for conversions.

**cgs system of units.** A system in which the basic units are the centimeter, gram, and second.<sup>2</sup>

**coercive force (coercive field).** The magnetic field strength (H) required to reduce the magnetic induction (B) in a magnetic material to zero.

**coercivity.** generally used to designate the magnetic field strength (H) required to reduce the magnetic induction (B) in a magnetic material to zero from saturation. The coercivity would be the upper limit to the coercive force.

**compliance voltage.** See current source.

**Curie temperature (T<sub>c</sub>).** Temperature at which a magnetized sample is completely demagnetized due to thermal agitation. Named for Pierre Curie (1859 – 1906), a French chemist.

**current source.** A type of power supply that supplies a constant current through a variable load resistance by automatically varying its compliance voltage. A single specification given as “compliance voltage” means the output current is within specification when the compliance voltage is between zero and the specified voltage.

**demagnetization.** when a sample is exposed to an applied field (H<sub>a</sub>), poles are induced on the surface of the sample. Some of the returned flux from these poles is inside of the sample. This returned flux tends to decrease the net magnetic field strength internal to the sample yielding a true internal field (H<sub>int</sub>) given by: H<sub>int</sub> = H<sub>a</sub> – DM, where M is the volume magnetization and D is the demagnetization factor. D is dependent on the sample geometry and orientation with respect to the field.

**deviation.** The difference between the actual value of a controlled variable and the desired value corresponding to the setpoint.<sup>1</sup>

**differential permeability.** The slope of a B versus H curve:  $\mu_d = dB/dH$ .

**differential susceptibility.** The slope of a M versus H curve:  $\chi_d = dM/dH$ .

**digital controller.** A feedback control system where the feedback device (sensor) and control actuator (heater) are joined by a digital processor. In Lake Shore controllers the heater output is maintained as a variable DC current source.

**digital data.** Pertaining to data in the form of digits or interval quantities. Contrast with analog data.<sup>2</sup>

**dimensionless sensitivity.** Sensitivity of a physical quantity to a stimulus, expressed in dimensionless terms. The dimensionless temperature sensitivity of a resistance temperature sensor is expressed as  $S_d = (T/R)(dR/dT)$  which is also equal to the slope of R versus T on a log-log plot, that is  $S_d = d \ln R / d \ln T$ . Note that the absolute temperature (in kelvin) must be used in these expressions.

**drift, instrument.** An undesired but relatively slow change in output over a period of time, with a fixed reference input.

*Note:* Drift is usually expressed in percent of the maximum rated value of the variable being measured.<sup>2</sup>

**dynamic data exchange (DDE).** A method of interprocess communication which passes data between processes and synchronized events. DDE uses shared memory to exchange data between applications and a protocol to synchronize the passing of data.

**dynamic link library (DLL).** A module that contains code, data, and Windows resources that multiple Windows programs can access.

**electromagnet.** A device in which a magnetic field is generated as the result of electrical current passing through a helical conducting coil. It can be configured as an iron-free solenoid in which the field is produced along the axis of the coil, or an iron-cored structure in which the field is produced in an air gap between pole faces. The coil can be water cooled copper or aluminum, or superconductive.

**electron.** An elementary particle containing the smallest negative electric charge. *Note:* The mass of the electron is approximately equal to 1/1837 of the mass of the hydrogen atom.<sup>2</sup>

**electrostatic discharge (ESD).** A transfer of electrostatic charge between bodies at different electrostatic potentials caused by direct contact or induced by an electrostatic field.

**error.** Any discrepancy between a computed, observed, or measured quantity and the true, specified, or theoretically correct value or condition.<sup>2</sup>

**Fahrenheit (°F) Scale.** A temperature scale that registers the freezing point of water as 32 °F and the boiling point as 212 °F under normal atmospheric pressure. See Temperature for conversions.

**flux (φ).** The electric or magnetic lines of force in a region.<sup>1</sup>

**gamma.** A cgs unit of low-level flux density, where 100,000 gamma equals one oersted, or 1 gamma equals 10<sup>-5</sup> oersted.

**gauss (G).** The cgs unit for magnetic flux density (B). 1 gauss = 10<sup>-4</sup> tesla = 1 Mx/cm<sup>2</sup> = line/cm<sup>2</sup>. Named for Karl Fredrich Gauss (1777 – 1855) a German mathematician, astronomer, and physicist.

**gaussian system (units).** A system in which centimeter-gram-second units are used for electric and magnetic qualities.

**general purpose interface bus (GPIB).** Another term for the IEEE-488 bus.

**gilbert (Gb).** A cgs electromagnetic unit of the magnetomotive force required to produce one maxwell of magnetic flux in a magnetic circuit of unit reluctance. One gilbert is equal to  $10/4\pi$  ampere-turn. Named for William Gilbert (1540–1603), an English physicist; hypothesized that the earth is a magnet.

**gilbert per centimeter.** Practical cgs unit of magnet intensity. Gilberts per cm are the same as oersteds.

**Greek alphabet.** The Greek alphabet is defined as follows:

Alpha	$\alpha$	A	Iota	$\iota$	I	Rho	$\rho$	P
Beta	$\beta$	B	Kappa	$\kappa$	K	Sigma	$\sigma$	$\Sigma$
Gamma	$\gamma$	$\Gamma$	Lambda	$\lambda$	$\Lambda$	Tau	$\tau$	T
Delta	$\delta$	$\Delta$	Mu	$\mu$	M	Upsilon	$\upsilon$	Y
Epsilon	$\epsilon$	E	Nu	$\nu$	N	Phi	$\phi$	$\Phi$
Zeta	$\zeta$	Z	Xi	$\xi$	$\Xi$	Chi	$\chi$	X
Eta	$\eta$	H	Omicron	$\omicron$	O	Psi	$\psi$	$\Psi$
Theta	$\theta$	$\Theta$	Pi	$\pi$	$\Pi$	Omega	$\omega$	$\Omega$

**ground.** A conducting connection, whether intentional or accidental, by which an electric circuit or equipment is connected to the earth, or to some conducting body of large extent that serves in place of the earth. *Note:* It is used for establishing and maintaining the potential of the earth (or of the conducting body) or approximately that potential, on conductors connected to it, and for conducting ground current to and from the earth (or of the conducting body).<sup>2</sup>

**H.** Symbol for magnetic field strength. See Magnetic Field Strength.

**Hall effect.** The generation of an electric potential perpendicular to both an electric current flowing along a thin conducting material and an external magnetic field applied at right angles to the current. Named for Edwin H. Hall (1855–1938), an American physicist.

**Hall mobility.** The quantity  $\mu_H$  in the relation  $\mu_H = R\sigma$ , where  $R$  = Hall coefficient and  $\sigma$  = conductivity.<sup>2</sup>

**Helmholtz coils.** A pair of flat, circular coils having equal numbers of turns and equal diameters, arranged with a common axis, and connected in series; used to obtain a magnetic field more nearly uniform than that of a single coil.<sup>1</sup>

**hertz (Hz).** A unit of frequency equal to one cycle per second.

**hole.** A mobile vacancy in the electronic valence structure of a semiconductor that acts like a positive electron charge with a positive mass.<sup>2</sup>

**hysteresis.** The dependence of the state of a system on its previous history, generally in the form of a lagging of a physical effect behind its cause.<sup>1</sup> Also see magnetic hysteresis.

**IEEE.** Institute of Electrical and Electronics Engineers.

**IEEE-488.** An instrumentation bus with hardware and programming standards designed to simplify instrument interfacing. The addressable, parallel bus specification is defined by the IEEE.

**initial permeability.** The permeability determined at  $H = 0$  and  $B = 0$ .

**initial susceptibility.** The susceptibility determined at  $H = 0$  and  $M = 0$ .

**integrator.** A circuit or network whose output waveform is the time integral of its input waveform.<sup>1</sup> In the Model 480, the input is a voltage with the integral output being in volt seconds (V·s).

**international system of units (SI).** A universal coherent system of units in which the following seven units are considered basic: meter, kilogram, second, ampere, kelvin, mole, and candela. The International System of Units, or *Système International d'Unités* (SI), was promulgated in 1960 by the Eleventh General Conference on Weights and Measures. For definition, spelling, and protocols, see Reference 3 for a short, convenient guide.

**interpolation table.** A table listing the output and sensitivity of a sensor at regular or defined points which may be different from the points at which calibration data was taken.

**intrinsic coercivity.** The magnetic field strength ( $H$ ) required to reduce the magnetization ( $M$ ) or intrinsic induction in a magnetic material to zero.

**intrinsic induction.** The contribution of the magnetic material ( $B_i$ ) to the total magnetic induction ( $B$ ).

$$B_i = B - \mu_0 H \quad (\text{SI}) \qquad B_i = B - H \quad (\text{cgs})$$

**isolated** (neutral system). A system that has no intentional connection to ground except through indicating, measuring, or protective devices of very-high impedance.<sup>2</sup>

**Kelvin (K).** The unit of temperature on the Kelvin Scale. It is one of the base units of SI. The word “degree” and its symbol (°) are omitted from this unit. See Temperature Scale for conversions.

**Kelvin Scale.** The Kelvin Thermodynamic Temperature Scale is the basis for all international scales, including the ITS-90. It is fixed at two points: the absolute zero of temperature (0 K), and the triple point of water (273.16 K), the equilibrium temperature that pure water reaches in the presence of ice and its own vapor.

**line regulation.** The maximum steady-state amount that the output voltage or current will change as the result of a specified change in input line voltage (usually for a step change between 105–125 or 210–250 volts, unless otherwise specified).

**line of flux.** An imaginary line in a magnetic field of force whose tangent at any point gives the direction of the field at that point; the lines are spaced so that the number through a unit area perpendicular to the field represents the intensity of the field. Also known as a Maxwell in the cgs system of units.

**line voltage.** The RMS voltage of the primary power source to an instrument.

**load regulation.** A steady-state decrease of the value of the specified variable resulting from a specified increase in load, generally from no-load to full-load unless otherwise specified.

**M.** Symbol for magnetization. See magnetization.

**magnetic air gap.** The air space, or non-magnetic portion, of a magnetic circuit.

**magnetic field strength (H).** The magnetizing force generated by currents and magnetic poles. For most applications, the magnetic field strength can be thought of as the applied field generated, for example, by a superconducting magnet. The magnetic field strength is not a property of materials. Measure in SI units of A/m or cgs units of oersted.

**magnetic flux density (B).** Also referred to as magnetic induction. This is the net magnetic response of a medium to an applied field, H. The relationship is given by the following equation:  $B = \mu_0(H + M)$  for SI, and  $B = H + 4\pi M$  for cgs, where H = magnetic field strength, M = magnetization, and  $\mu_0 = \text{permeability of free space} = 4\pi \times 10^{-7} \text{ H/m}$ .

**magnetic hysteresis.** The property of a magnetic material where the magnetic induction (B) for a given magnetic field strength (H) depends upon the past history of the samples magnetization.

**magnetic induction (B).** See magnetic flux density.

**magnetic moment (m).** This is the fundamental magnetic property measured with dc magnetic measurements systems such as a vibrating sample magnetometer, extraction magnetometer, SQUID magnetometer, etc. The exact technical definition relates to the torque exerted on a magnetized sample when placed in a magnetic field. Note that the moment is a total attribute of a sample and alone does not necessarily supply sufficient information in understanding material properties. A small highly magnetic sample can have exactly the same moment as a larger weakly magnetic sample (see Magnetization). Measured in SI units as  $\text{A}\cdot\text{m}^2$  and in cgs units as emu.  $1 \text{ emu} = 10^{-3} \text{ A}\cdot\text{m}^2$ .

**magnetic scalar potential.** The work which must be done against a magnetic field to bring a magnetic pole of unit strength from a reference point (usually at infinity) to the point in question. Also known as magnetic potential.<sup>1</sup>

**magnetic units.** Units used in measuring magnetic quantities. Includes ampere-turn, gauss, gilbert, line of force, maxwell, oersted, and unit magnetic pole.

**magnetization (M).** This is a material specific property defined as the magnetic moment (m) per unit volume (V).  $M = m/V$ . Measured in SI units as A/m and in cgs units as  $\text{emu}/\text{cm}^3$ .  $1 \text{ emu}/\text{cm}^3 = 10^3 \text{ A/m}$ . Since the mass of a sample is generally much easier to determine than the volume, magnetization is often alternately expressed as a mass magnetization defined as the moment per unit mass.

**magnetostatic.** Pertaining to magnetic properties that do not depend upon the motion of magnetic fields.<sup>1</sup>

**mains.** See line voltage.

**Maxwell (Mx).** A cgs electromagnetic unit of magnetic flux, equal to the magnetic flux which produces an electromotive force of 1 abvolt in a circuit of one turn link the flux, as the flux is reduced to zero in 1 second at a uniform rate.<sup>1</sup>

**MKSA System of Units.** A system in which the basic units are the meter, kilogram, and second, and the ampere is a derived unit defined by assigning the magnitude  $4\pi \times 10^{-7}$  to the rationalized magnetic constant (sometimes called the permeability of space).

**NBS.** National Bureau of Standards. Now referred to as NIST.

**National Institute of Standards and Technology (NIST).** Government agency located in Gaithersburg, Maryland and Boulder, Colorado, that defines measurement standards in the United States. See Standards Laboratories for an international listing.

**noise (electrical).** Unwanted electrical signals that produce undesirable effects in circuits of control systems in which they occur.<sup>2</sup>

**normalized sensitivity.** For resistors, signal sensitivity ( $dR/dT$ ) is geometry dependent; i.e.,  $dR/dT$  scales directly with R; consequently, often this sensitivity is normalized by dividing by the measured resistance to give a sensitivity,  $s_T$ , in percent change per kelvin.  $s_T = (100/R) (dR/dT) \%K$ , where T is the temperature in kelvin and R is the resistance in ohms.

**normally closed (N.C.).** A term used for switches and relay contacts. Provides a closed circuit when actuator is in the free (unenergized) position.

**normally open (N.O.).** A term used for switches and relay contacts. Provides an open circuit when actuator is in the free (unenergized) position.

**oersted (Oe).** The cgs unit for the magnetic field strength (H).  $1 \text{ oersted} = 10^3/4\pi \text{ ampere}/\text{meter} \approx 79.58 \text{ ampere}/\text{meter}$ .

**ohm ( $\Omega$ ).** The SI unit of resistance (and of impedance). The ohm is the resistance of a conductor such that a constant current of one ampere in it produces a voltage of one volt between its ends.<sup>2</sup>

**pascal (Pa).** The SI unit of pressure equal to  $1 \text{ N}/\text{m}^2$ . Equal to  $1.45 \times 10^{-4} \text{ psi}$ ,  $1.0197 \times 10^{-5} \text{ kgf}/\text{cm}^2$ ,  $7.5 \times 10^{-3} \text{ torr}$ ,  $4.191 \times 10^{-3} \text{ inches of water}$ , or  $1 \times 10^{-5} \text{ bar}$ .

**permeability.** Material parameter which is the ratio of the magnetic induction (B) to the magnetic field strength (H):  
 $\mu = B/H$ . Also see Initial Permeability and Differential Permeability.

**polynomial fit.** A mathematical equation used to fit calibration data. Polynomials are constructed of finite sums of terms of the form  $a_i x_i$ , where  $a_i$  is the  $i^{\text{th}}$  fit coefficient and  $x_i$  is some function of the dependent variable.

**pounds per square inch (psi).** A unit of pressure. 1 psi = 6.89473 kPa. Variations include psi absolute (psia) measured relative to vacuum (zero pressure) where one atmosphere pressure equals 14.696 psia and psi gauge (psig) where gauge measured relative to atmospheric or some other reference pressure.

**ppm.** Parts per million, e.g.,  $4 \times 10^{-6}$  is four parts per million.

**precision.** Careful measurement under controlled conditions which can be repeated with similar results. See repeatability. Also means that small differences can be detected and measured with confidence. See resolution.

**prefixes.** SI prefixes used throughout this manual are as follows:

Factor	Prefix	Symbol	Factor	Prefix	Symbol
$10^{24}$	yotta	Y	$10^{-1}$	deci	d
$10^{21}$	zetta	Z	$10^{-2}$	centi	c
$10^{18}$	exa	E	$10^{-3}$	milli	m
$10^{15}$	peta	P	$10^{-6}$	micro	$\mu$
$10^{12}$	tera	T	$10^{-9}$	nano	n
$10^9$	giga	G	$10^{-12}$	pico	p
$10^6$	mega	M	$10^{-15}$	femto	f
$10^3$	kilo	k	$10^{-18}$	atto	a
$10^2$	hecto	h	$10^{-21}$	zepto	z
$10^1$	deka	da	$10^{-24}$	yocto	y

**probe.** A long, thin body containing a sensing element which can be inserted into a system in order to make measurements. Typically, the measurement is localized to the region near the tip of the probe.

**remanence.** The remaining magnetic induction in a magnetic material when the material is first saturated and then the applied field is reduced to zero. The remanence would be the upper limit to values for the remanent induction. Note that no strict convention exists for the use of remanent induction and remanence and in some contexts the two terms may be used interchangeably.

**remanent induction.** The remaining magnetic induction in a magnetic material after an applied field is reduced to zero. Also see remanence.

**repeatability.** The closeness of agreement among repeated measurements of the same variable under the same conditions.<sup>2</sup>

**resolution.** The degree to which nearly equal values of a quantity can be discriminated.<sup>2</sup>

**display resolution.** The resolution of the physical display of an instrument. This is not always the same as the measurement resolution of the instrument. Decimal display resolution specified as " $n$  digits" has  $10^n$  possible display values. A resolution of  $n$  and one-half digits has  $2 \times 10^n$  possible values.

**measurement resolution.** The ability of an instrument to resolve a measured quantity. For digital instrumentation this is often defined by the analog to digital converter being used. A  $n$ -bit converter can resolve one part in  $2^n$ . The smallest signal change that can be measured is the full scale input divided by  $2^n$  for any given range. Resolution should not be confused with accuracy.

**root mean square (RMS).** The square root of the time average of the square of a quantity; for a periodic quantity the average is taken over one complete cycle. Also known as effective value.<sup>1</sup>

**RS-232C.** Bi-directional computer serial interface standard defined by the Electronic Industries Association (EIA). The interface is single-ended and non-addressable.

**scalar.** A quantity which has magnitude only and no direction, in contrast to a vector.<sup>1</sup>

**semiconducting material.** A conducting medium in which the conduction is by electrons, and holes, and whose temperature coefficient of resistivity is negative over some temperature range below the melting point.<sup>2</sup>

**semiconductor.** An electronic conductor, with resistivity in the range between metals and insulators, in which the electric charge carrier concentration increases with increasing temperature over some temperature range. *Note:* Certain semiconductors possess two types of carriers, namely, negative electrons and positive holes.<sup>2</sup>

**sensitivity.** The ratio of the response or change induced in the output to a stimulus or change in the input. Temperature sensitivity of a resistance temperature detector is expressed as  $S = dR/dT$ .

**setpoint.** The value selected to be maintained by an automatic controller.<sup>1</sup>

**serial interface.** A computer interface where information is transferred one bit at a time rather than one byte (character) at a time as in a parallel interface. RS-232C is a common serial interface.

**SI.** Système International d'Unités. See International System of Units.

**stability.** The ability of an instrument or sensor to maintain a constant output given a constant input.

**susceptance.** In electrical terms, susceptance is defined as the reciprocal of reactance and the imaginary part of the complex representation of admittance: [suscept(ibility) + (conduct)ance].

**susceptibility ( $\chi$ ).** Parameter giving an indication of the response of a material to an applied magnetic field. The susceptibility is the ratio of the magnetization (M) to the applied field (H).  $\chi = M/H$ . In both SI units and cgs units the volume susceptibility is a dimensionless parameter. Multiply the cgs susceptibility by  $4\pi$  to yield the SI susceptibility. See also Initial Susceptibility and Differential Susceptibility. As in the case of magnetization, the susceptibility is often seen expressed as a mass susceptibility or a molar susceptibility depending upon how M is expressed.

**temperature scales.** See Kelvin Scale, Celsius Scale, and ITS-90. Proper metric usage requires that only kelvin and degrees Celsius be used. However, since degrees Fahrenheit is in such common use, all three scales are delineated as follows:

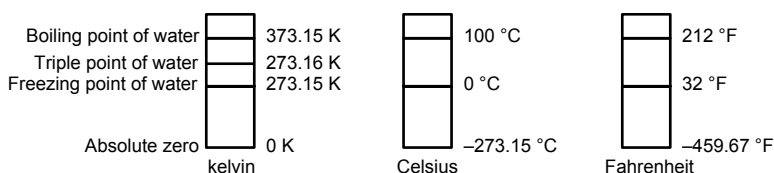

To convert kelvin to Celsius, subtract 273.15.

To convert Celsius to Fahrenheit: multiply °C by 1.8 then add 32, or:  $^{\circ}\text{F} = (1.8 \times ^{\circ}\text{C}) + 32$ .

To convert Fahrenheit to Celsius: subtract 32 from °F then divide by 1.8, or:  $^{\circ}\text{C} = (^{\circ}\text{F} - 32) / 1.8$ .

**temperature coefficient, measurement.** The measurement accuracy of an instrument is affected by changes in ambient temperature. The error is specified as an amount of change (usually in percent) for every one degree change in ambient temperature.

**tesla (T).** The SI unit for magnetic flux density (B). 1 tesla =  $10^4$  gauss

**thermal emf.** An electromotive force arising from a difference in temperature at two points along a circuit, as in the Seebeck effect.<sup>1</sup>

**tolerance.** The range between allowable maximum and minimum values.

**turns (N).** One complete loop of wire. In the Model 480, the turns of a coil must be entered to perform flux measurements in units of Volt seconds ( $V \cdot \phi$ ), Webers ( $\text{Wb} \cdot \phi$ ), or Maxwells ( $\text{Mx} \cdot \phi$ ).

**Underwriters Laboratories (UL).** An independent laboratory that establishes standards for commercial and industrial products.

**unit magnetic pole.** A pole with a strength such that when it is placed 1 cm away from a like pole, the force between the two is 1 dyne.

**vector.** A quantity that has both magnitude and direction, and whose components transform from one coordinate system to another in the same manner as the components of a displacement. Also known as a polar vector.<sup>1</sup>

**volt (V).** The difference of electric potential between two points of a conductor carrying a constant current of one ampere, when the power dissipated between these points is equal to one watt.<sup>2</sup>

**volt-ampere (VA).** The SI unit of apparent power. The volt-ampere is the apparent power at the points of entry of a single-phase, two-wire system when the product of the RMS value in amperes of the current by the RMS value in volts of the voltage is equal to one.<sup>2</sup>

**volt-second (v·s).** A voltage of 1 volt (V) present at the input of a fluxmeter for 1 second (s) results in a reading of 1 volt-second (v·s). Volt-seconds are the primary unit of measurement for an integrator. See Weber.

**watt (W).** The SI unit of power. The watt is the power required to do work at the rate of 1 joule per second.<sup>2</sup>

**weber (Wb).** The unit of magnetic flux in the mks system, equal to the magnetic flux which, linking a circuit of one turn, produces in it an electromotive force of 1 volt as it is reduced to zero at a uniform rate in 1 second.<sup>1</sup>

#### References:

- 1 Sybil P. Parker, Editor. *Dictionary of Scientific and Technical Terms: Fifth Edition*. New York: McGraw Hill, 1994 (ISBN 0-07-042333-4).
- 2 Christopher J. Booth, Editor. *The New IEEE Standard Dictionary of Electrical and Electronic Terms: IEEE Std 100-1992, Fifth Edition*. New York: Institute of Electrical and Electronics Engineers, 1993 (ISBN 1-55937-240-0). Definitions printed with permission of the IEEE.
- 3 Nelson, Robert A. *Guide For Metric Practice*, Page BG7 - 8, Physics Today, Eleventh Annual Buyer's Guide, August 1994 (ISSN 0031-9228 coden PHTOAD)

# APPENDIX B

## REFERENCE INFORMATION

Table B-1. Conversion from CGS to SI Units

Quantity	Symbol	Gaussian & CGS emu <sup>a</sup>	Conversion Factor, C <sup>b</sup>	SI & Rationalized mks <sup>c</sup>
Magnetic flux density, Magnetic induction	B	gauss (G) <sup>d</sup>	10 <sup>-4</sup>	tesla (T), Wb/m <sup>2</sup>
Magnetic Flux	φ	maxwell (Mx), G·cm <sup>2</sup>	10 <sup>-8</sup>	weber (Wb), volt second (V·s)
Magnetic potential difference, magnetomotive force	U, F	gilbert (Gb)	10/4π	ampere (A)
Magnetic field strength, magnetizing force	H	oersted (Oe), <sup>e</sup> Gb/cm	10 <sup>3</sup> /4π	A/m <sup>f</sup>
(Volume) magnetization <sup>g</sup>	M	emu/cm <sup>3h</sup>	10 <sup>3</sup>	A/m
(Volume) magnetization	4πM	G	10 <sup>3</sup> /4π	A/m
Magnetic polarization, intensity of magnetization	J, I	emu/cm <sup>3</sup>	4π × 10 <sup>-4</sup>	T, Wb/m <sup>2i</sup>
(Mass) magnetization	σ, M	emu/g	$\frac{1}{4\pi \times 10^{-7}}$	A·m <sup>2</sup> /kg Wb·m/kg
Magnetic moment	m	emu, erg/G	10 <sup>-3</sup>	A·m <sup>2</sup> , joule per tesla (J/T)
Magnetic dipole moment	j	emu, erg/G	4π × 10 <sup>-10</sup>	Wb·m <sup>l</sup>
(Volume) susceptibility	χ, κ	dimensionless emu/cm <sup>3</sup>	$\frac{1}{(4\pi)^2 \times 10^{-7}}$	Henry per meter (H/m), Wb/(A·m)
(Mass) susceptibility	χ <sub>p</sub> , κ <sub>p</sub>	cm <sup>3</sup> /g, emu/g	$\frac{4\pi \times 10^{-3}}{(4\pi)^2 \times 10^{-10}}$	m <sup>3</sup> /kg H·m <sup>2</sup> /kg
(Molar) susceptibility	χ <sub>mol</sub> , κ <sub>mol</sub>	cm <sup>3</sup> /mol, emu/mol	$\frac{4\pi \times 10^{-6}}{(4\pi)^2 \times 10^{-13}}$	m <sup>3</sup> /mol H·m <sup>2</sup> /mol
Permeability	μ	dimensionless	4π × 10 <sup>-7</sup>	H/m, Wb/(A·m)
Relative permeability <sup>j</sup>	μ <sub>r</sub>	not defined	—	dimensionless
(Volume) energy density, energy product <sup>k</sup>	W	erg/cm <sup>3</sup>	10 <sup>-1</sup>	J/m <sup>3</sup>
Demagnetization factor	D, N	dimensionless	1/4π	dimensionless

**NOTES:**

- Gaussian units and cgs emu are the same for magnetic properties. The defining relation is  $B = H + 4\pi M$ .
- Multiply a number in Gaussian units by C to convert it to SI (e.g.  $1 \text{ G} \times 10^{-4} \text{ T/G} = 10^{-4} \text{ T}$ ).
- SI (Système International d'Unités) has been adopted by the National Bureau of Standards. Where two conversion factors are given, the upper one is recognized under, or consistent with, SI and is based on the definition  $B = \mu_0(H + M)$ , where to  $\mu_0 = 4\pi \times 10^{-7} \text{ H/m}$ . The lower one is not recognized under SI and is based on the definition  $B = \mu_0 H + J$ , where the symbol I is often used in place of J.
- $1 \text{ gauss} = 10^5 \text{ gamma } (\gamma)$ .
- Both oersted and gauss are expressed as  $\text{cm}^{-3/2} \text{ g}^{1/2} \text{ s}^{-1}$  in terms of base units.
- A/m was often expressed as "ampere-turn per meter" when used for magnetic field strength.
- Magnetic moment per unit volume.
- The designation "emu" is not a unit.
- Recognized under SI, even though based on the definition  $B = \mu_0 H + J$ . Refer to note c.
- $\mu_r = \mu/\mu_0 = 1 + \chi$ , all in SI.  $\mu_r$  is equal to Gaussian  $\mu$ .
- $B \cdot H$  and  $\mu_0 M \cdot H$  have SI units  $\text{J/m}^3$ ,  $\text{M} \cdot \text{H}$  and  $B \cdot H/4\pi$  have Gaussian units  $\text{erg/cm}^3$ .

R.B. Goldfarb and F.R. Fickett, U.S. Department of Commerce, National Bureau of Standards, Boulder, Colorado 80303, March 1985, NBS Special Publication 696. For sale by the Superintendent of Documents, U.S. Government Printing Office, Washington, D.C. 20402.

**Table B-2. Recommended SI Values for Physical Constants**

Quantity	Symbol	Value (SI units)
Permeability of Vacuum	$\mu_0$	$4\pi \times 10^{-7} \text{ H m}^{-1}$
Speed of Light in Vacuum	$c$	$2.9979 \times 10^8 \text{ m s}^{-1}$
Permittivity of Vacuum	$\epsilon_0 = (\mu_0 c^2)^{-1}$	$8.8542 \times 10^{-12} \text{ F m}^{-1}$
Fine Structure Constant, $\mu_0 c e^2 / 2h$	$\alpha$ $\alpha^{-1}$	0.0073 137.0360
Elementary Charge	$e$	$1.6022 \times 10^{-19} \text{ C}$
Planck's Constant	$h$ $\hbar = h/2\pi$	$6.6262 \times 10^{-34} \text{ J Hz}^{-1}$ $1.0546 \times 10^{-34} \text{ J s}$
Avogadro's Constant	$N_A$	$6.0220 \times 10^{23} \text{ mol}^{-1}$
Atomic Mass Unit	$1 \text{ u} = 10^{-3} \text{ kg mol}^{-1} / N_A$	$1.6605 \times 10^{-27} \text{ kg}$
Electron Rest Mass	$m_e$	$0.9109 \times 10^{-30} \text{ kg}$ $5.4858 \times 10^{-4} \text{ u}$
Proton Rest Mass	$m_p$	$1.6726 \times 10^{-27} \text{ kg}$ $1.0073 \text{ u}$
Neutron Rest Mass	$m_n$	$1.6749 \times 10^{-27} \text{ kg}$ $1.0087 \text{ u}$
Magnetic Flux Quantum	$\phi = h/2e$ $h/e$	$2.0679 \times 10^{-15} \text{ Wb}$ $4.1357 \times 10^{-15} \text{ J Hz}^{-1} \text{ C}^{-1}$
Josephson Frequency-Voltage Ratio	$2e/h$	$483.5939 \text{ THz V}^{-1}$
Quantum of Circulation	$h/2m_e$ $h/m_e$	$3.6369 \times 10^{-4} \text{ J Hz}^{-1} \text{ kg}^{-1}$ $7.2739 \times 10^{-4} \text{ J Hz}^{-1} \text{ C}^{-1}$
Rydberg Constant	$R_\infty$	$1.0974 \times 10^7 \text{ m}^{-1}$
Proton Moment in Nuclear Magnetons	$\mu_p / \mu_N$	2.7928
Bohr Magneton	$\mu_B = eh/2m_e$	$9.2741 \times 10^{-24} \text{ J T}^{-1}$
Proton Gyromagnetic Ratio	$\gamma_p$	$2.6752 \times 10^8 \text{ s}^{-1} \text{ T}^{-1}$
Diamagnetic Shielding Factor, Spherical H <sub>2</sub> O Sample	$1 + \sigma(\text{H}_2\text{O})$	1.0000
Molar Mass Constant	$R$	$8.3144 \text{ J mol}^{-1} \text{ K}^{-1}$
Molar Volume, Ideal Gas ( $T_0 = 273.15\text{K}$ , $p_0 = 1 \text{ atm}$ )	$V_m = RT_0/p_0$	$0,0224 \text{ m}^3 \text{ mol}^{-1}$
Boltzman Constant	$k = R/N_A$	$1.3807 \times 10^{-23} \text{ J K}^{-1}$
Stefan-Boltzman Constant	$\sigma = (\pi^2/60) k^4/h^3 c^2$	$5.6703 \times 10^{-8} \text{ W m}^{-2} \text{ K}^{-4}$
First Radiation Constant	$c_1 = 2\pi h c^2$	$3.7418 \times 10^{-16} \text{ W m}^{-2}$
Second Radiation Constant	$c_2 = hc/k$	0.0144 mK
Gravitation Constant	$G$	$6.6720 \times 10^{-11} \text{ N m}^2 \text{ kg}^{-2}$

Data (abbreviated to 4 decimal places) from CODATA Bulletin No. 11, ICSU CODATA Central Office, 19 Westendstrasse, 6 Frankfurt/Main, Germany. Copies of this bulletin are available from this office.